

Technical Information

Gammapilot M FMG60

Radiometric Measurement



Compact transmitter for non-contact level, point level and density detection

Application

- Continuous, non-contact measurement in liquids, solids, suspensions or sludges etc.
- Applications under extreme measuring conditions, e.g. high pressure, high temperature, corrosiveness, toxicity, abrasion
- All kinds of process vessels, e.g. reactors, autoclaves, separators, acid tanks, mixers, cyclones, cupola furnaces
- Applications in food processing industry without additional requirements or approvals
- System integration via HART, PROFIBUS PA and FOUNDATION Fieldbus
- Use in safety functions for max. point level detection and min. point level detection

Your benefits

- Compact transmitter: one instrument for all measuring tasks
- Highest availability, reliability and safety, even for extreme process and ambient conditions
- Highest sensitivity and accuracy at lowest dose rates (ALARA principle)
- Optimum adjustment to the respective application via a variety of detectors:
 - point detector
 - rod detectors of different lengths
- Ex d, Ex e or Ex i current output for simple plant integration
- Stainless steel housing 316L for heavy-duty applications
- SIL2/3 approval in accordance with IEC 61508 for max. point level detection and min. point level detection
- WHG approval
- Temperature compensation for density measurements
- Gammagraphy detection
- Easy menu-guided onsite operation via four-line plain text display
- Easy commissioning, documentation and maintenance/diagnosis with the operating program FieldCare





Table of Contents

Document information	3	Shock resistance	26
Symbols	3	Electromagnetic compatibility	27
Function and system design	5	Water cooling	27
Measuring principle	5	Collimator	30
Measuring system	6	Collimator	30
Signal evaluation	8	Process conditions	30
System Integration	11	Process temperature	30
Input	14	Process pressure	30
Measured variable	14	Mechanical construction	31
Sensitivity	14	Dimensions, Weight	31
Typical pulse rates	15	Material	32
Measuring range	15	Human Interface	34
Temperature input (PT100) for density measurements	16	Display and operating unit FHX40	34
Output	17	Remote operation	35
Output signal	17	Certificates and Approvals	36
Error signal	17	Safety Manual (SIL 2/3)	36
Load	17	Ex approval	36
Output damping	17	External standards and guidelines	36
Power supply	17	Certificates	37
Supply voltage	17	Ordering information	40
Power consumption	17	Ordering information	40
Overtoltage category	17	Accessories	41
Protective class	17	Commubox FXA195 HART	41
Potential equalization	17	Commubox FXA291	41
Electrical connection	18	ToF Adapter FXA291	41
Connection compartments	18	Field Xpert SFX100	41
Cable entries	18	Remote display FHX40	42
Potential equalisation	18	Mounting device FHG60 (for level measurement and level limit measurement)	44
Terminal assignment	19	Clamping device for density measurement FHG61	46
Connector	20	Measurement section for density measurement FHG62	46
Performance characteristics/Stability	22	Supplementary documentation for Gammapilot M	47
Response time	22	Fields of Activities	47
Reference operating conditions	22	Technical Information	47
Measured value resolution	22	Operating Instructions	47
Influence of ambient temperature	22	Safety Manual	47
Statistical fluctuation of the radioactive decay	22	Clamping device for density measurement FHG61	47
Installation conditions	23	Measurement section for density measurement FHG62	47
Installation conditions for level measurement	23	Supplementary documentation for Radiation Sources, Source Containers and Modulator	48
Installation conditions for point level detection	24	Gamma Radiation Source FSG60, FSG61	48
Installation conditions for density and concentration measurement	25	Source container FQG60	48
Empty pipe detection	26	Source container FQG61, FQG62	48
Environment	26	Source container FQG63	48
Ambient temperature	26	Gammapilot FTG20	48
Climate class	26	Source container QG2000	48
Installation height as per IEC 61010-1 Ed.3	26	Gamma Modulator FHG65	48
Degree of protection	26		
Vibration resistance	26		



Document information

Symbols





Safety symbols

Symbol	Meaning
 <small>A0011189-DE</small>	DANGER! This symbol alerts you to a dangerous situation. Failure to avoid this situation will result in serious or fatal injury.
 <small>A0011190-DE</small>	WARNING! This symbol alerts you to a dangerous situation. Failure to avoid this situation can result in serious or fatal injury.
 <small>A0011191-DE</small>	CAUTION! This symbol alerts you to a dangerous situation. Failure to avoid this situation can result in minor or medium injury.
 <small>A0011192-DE</small>	NOTICE! This symbol contains information on procedures and other facts which do not result in personal injury.



Electrical symbols

Symbol	Meaning
 <small>A0018338</small>	Ground connection A grounded terminal which, as far as the operator is concerned, is grounded via a grounding system..
 <small>A0018339</small>	Protective ground connection A terminal which must be connected to ground prior to establishing any other connections.

Symbols for certain types of information

Symbol	Meaning
 <small>A0011182</small>	Allowed Indicates procedures, processes or actions that are allowed.
 <small>A0011183</small>	Preferred Indicates procedures, processes or actions that are preferred.
 <small>A0011184</small>	Forbidden Indicates procedures, processes or actions that are forbidden.
 <small>A0011193</small>	Tip Indicates additional information.
 <small>A0015484</small>	Reference to page Refers to the corresponding page number.

Symbols in graphics

Symbol	Meaning
1, 2, 3, 4, ...	Item numbers
A, B, C, D, ...	Views
 <small>A0011187</small>	Hazardous area Indicates a hazardous area.
 <small>A0011188</small>	Safe area (non-hazardous area) Indicates a non-hazardous location.

Function and system design

Measuring principle

The radiometric measuring principle is based on the fact that gamma radiation is attenuated when it penetrates a material. Radiometric measurement can be applied for different measuring tasks:

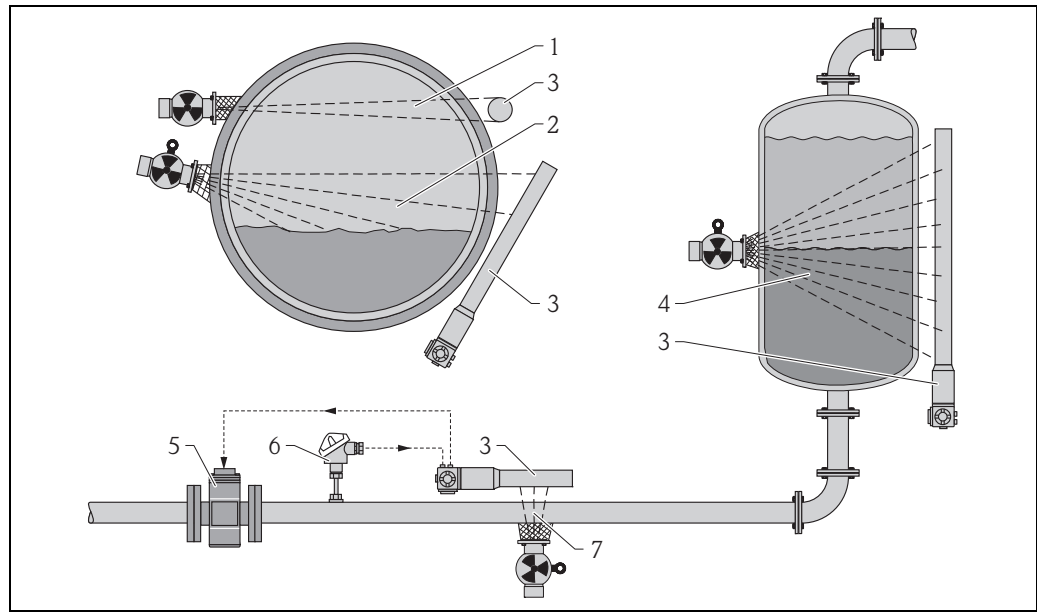

- | | | | |
|---|------------------------------|---|--------------------------------------|
| 1 | Point level detection | 5 | Volume flow meter |
| 2 | Continuous level measurement | 6 | Temperature sensor |
| 3 | Gammapilot M | 7 | Density or concentration measurement |
| 4 | Interface measurement | | |

Point level detection

A gamma radiation source and a Gammapilot M are mounted on opposite sides of the vessel at the height of the desired level limit. The Gammapilot M converts the received radiation intensity into a percentage. "0%" means that the radiation path is completely free, i.e. the level is below the limit. "100%" means that the radiation path is completely covered, i.e. the level is above the limit.

Continuous level measurement

A gamma radiation source and a Gammapilot M are mounted on opposite sides of the vessel. The Gammapilot M calculates the level (percentage) from the radiation intensity. Detectors of different lengths are available to adapt the system to the measuring range. Also, multiple detectors can be interconnected (cascading).

Interface measurement

A gamma radiation source and a Gammapilot M are mounted on opposite sides of the vessel in a height such that both liquids are irradiated. The radiation source may also be mounted inside the vessel. The Gammapilot M calculates the position of the interface layer from the intensity of the received radiation. Its value is between 0% (lowest possible position) and 100% (highest possible position).

Density or concentration measurement

A gamma radiation source and a Gammapilot M are mounted on opposite sides of a measuring tube. The Gammapilot M calculates the density or concentration of the medium from the intensity of the received radiation. The unit can be freely selected.

If an additional temperature sensor is connected, the Gammapilot M accounts for the thermal expansion of the medium. That means, it does not output the measured density directly. Instead it calculates the density which the medium would have at a certain standard temperature defined by the user.

Furthermore, the density signal of the Gammapilot M can be combined with the signal of a volume flow meter, e.g. Promag 55S. From these two signals it is possible to calculate the mass flow.

Measuring system

A radiometric measuring system typically consists of the following components:

Gamma Radiation Source

A ^{137}Cs or ^{60}Co isotope is used as the gamma radiation source. Gamma radiation sources with different activities are available to adapt the system to the application in question. The "Applicator"¹⁾ program can be used to calculate the required activity.

For further information on gamma radiation sources refer to TI00439F/00/EN.

Source Container

The radiation source is enclosed in a source container, which allows the radiation to be emitted only in one direction and screens it off in any other direction. Source containers of different sizes and with different radiation exit angles are available. The "Applicator"¹⁾ program can be used to select the source container that suits your application.

For further information on source containers refer to TI00445F/00/EN (FQG60), TI00435F/00/EN (FQG61, FQG62), TI00446F/00/EN (FQG63) and TI00346F/00/EN (QG2000).

Compact transmitter Gammapilot M

The compact transmitter Gammapilot M contains a scintillator, a photomultiplier and the evaluation circuit. Incident radiation generates light flashes within the scintillator. The photomultiplier converts these flashes into electrical pulses and amplifies them. The pulse rate (number of pulses per second) is a measure of the radiation intensity. Depending on the calibration, the pulse rate is converted to a level, limit, density or concentration signal by the evaluation circuit.

The Gammapilot M is available with a NaI-crystal or with plastic scintillators of different lengths. Thus, optimum adaptation to each individual application is ensured.

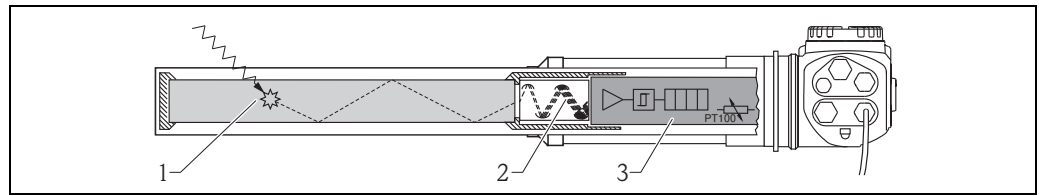

A0018244

- 1 Gamma radiation generates light flashes within the scintillator
- 2 The photomultiplier converts the flashes into electrical pulses and amplifies them
- 3 The evaluation circuit calculates the measured value from the pulse rate

1) The "Applicator" CD-ROM is available from your Endress+Hauser sales organization.

Gamma Modulator FHG65 (option)

In a radiometric measuring point with Gammapilot FMG60, the Gamma Modulator FHG65 is mounted in front of the radiation exit channel of the source container. It contains a shaft slotted along the longitudinal axis.

This shaft rotates continuously and alternately screens off the gamma beam at a frequency of 1 Hz or allows it through.

Due to this frequency, the useful beam differs from fluctuating ambient interference radiation and from interference radiation occurring sporadically (e.g. from nondestructive material testing). Using a frequency filter, the Gammapilot M FMG60 can thus separate the useful signal from interference radiation. In this way, it is possible to continue measuring even if interference radiation occurs, which, in turn, increases the measuring certainty and system availability.

For details please refer to TI00423F/00/EN.

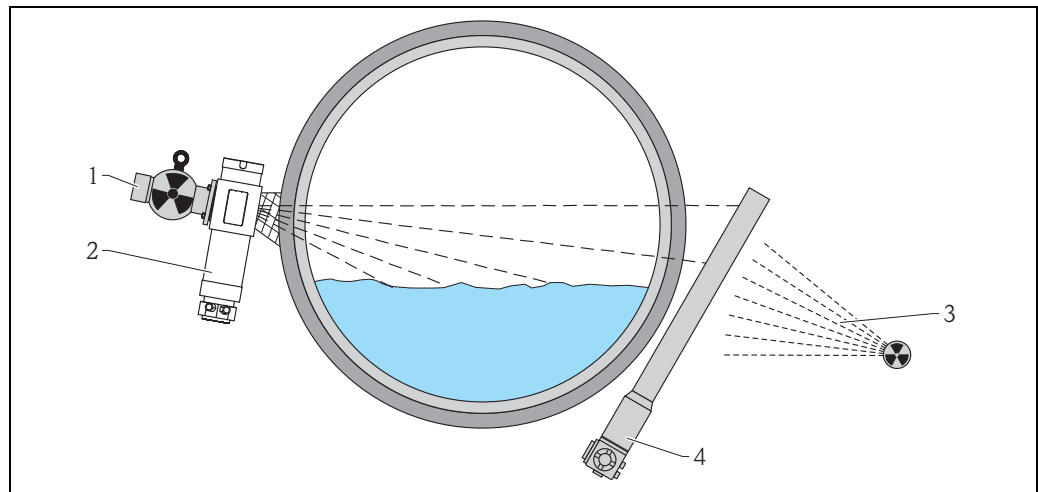

- 1 FQG61, FQG62
 2 FHG65
 3 Interference radiation
 4 Gammapilot M FMG60

NOTICE

The Gamma Modulator FHG65 and the Gammapilot M FMG60 are not interconnected electrically. When commissioning the Gammapilot FMG60, the "beam type" (*02) parameter must be set to "modulated".

Signal evaluation

Level measurement

A standard linearization table for the calculation of the level in vertical cylinders is preprogrammed in the Gammapilot M. For other situations a linearization table consisting of up to 32 points can be entered manually or half-automatically (by filling the vessel under controlled conditions). The linearization curve with its associated table can be calculated by the selection and configuration software "Applicator"²⁾.

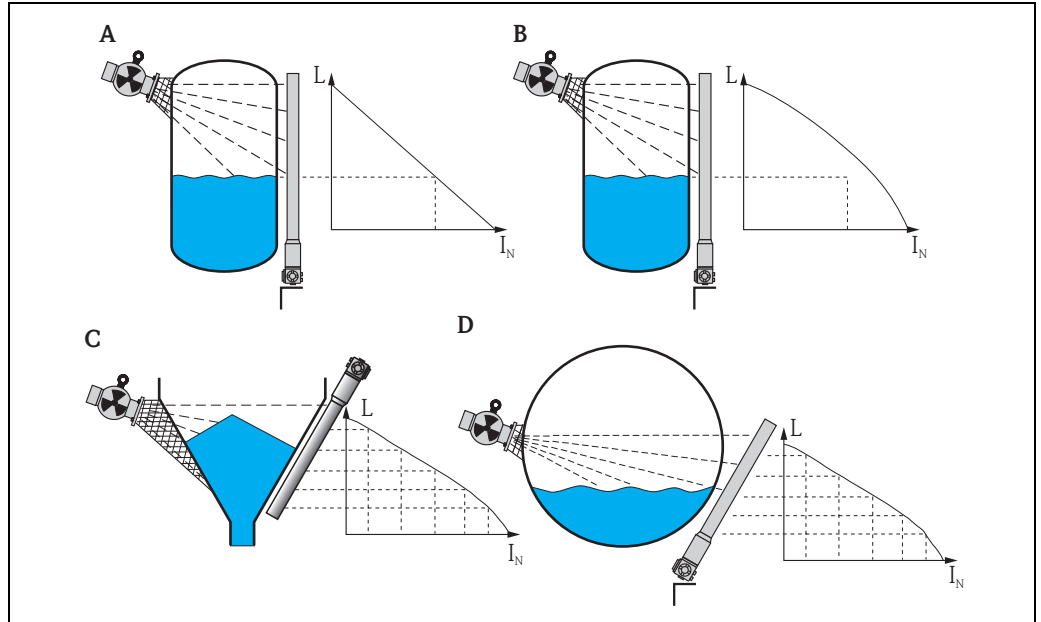

A0018246

- A Linear
- B Standard
- C, D Linearization table entered by the user

- I_N Pulse rate (counts per second, c/s)
- L Level (%)

2) The "Applicator" CD-ROM is available from your Endress+Hauser sales organization.

Wiring example for point level detection 200/400 mm

The output signal is linear between the free and covered calibration (e.g. 4 to 20 mA) and can be evaluated in the control system. If a relay output is needed, the following Endress+Hauser process transmitters can be used:

- RTA421: for non-Ex applications, without WHG, without SIL
- RMA42: for Ex-applications; with WHG and SIL certificates

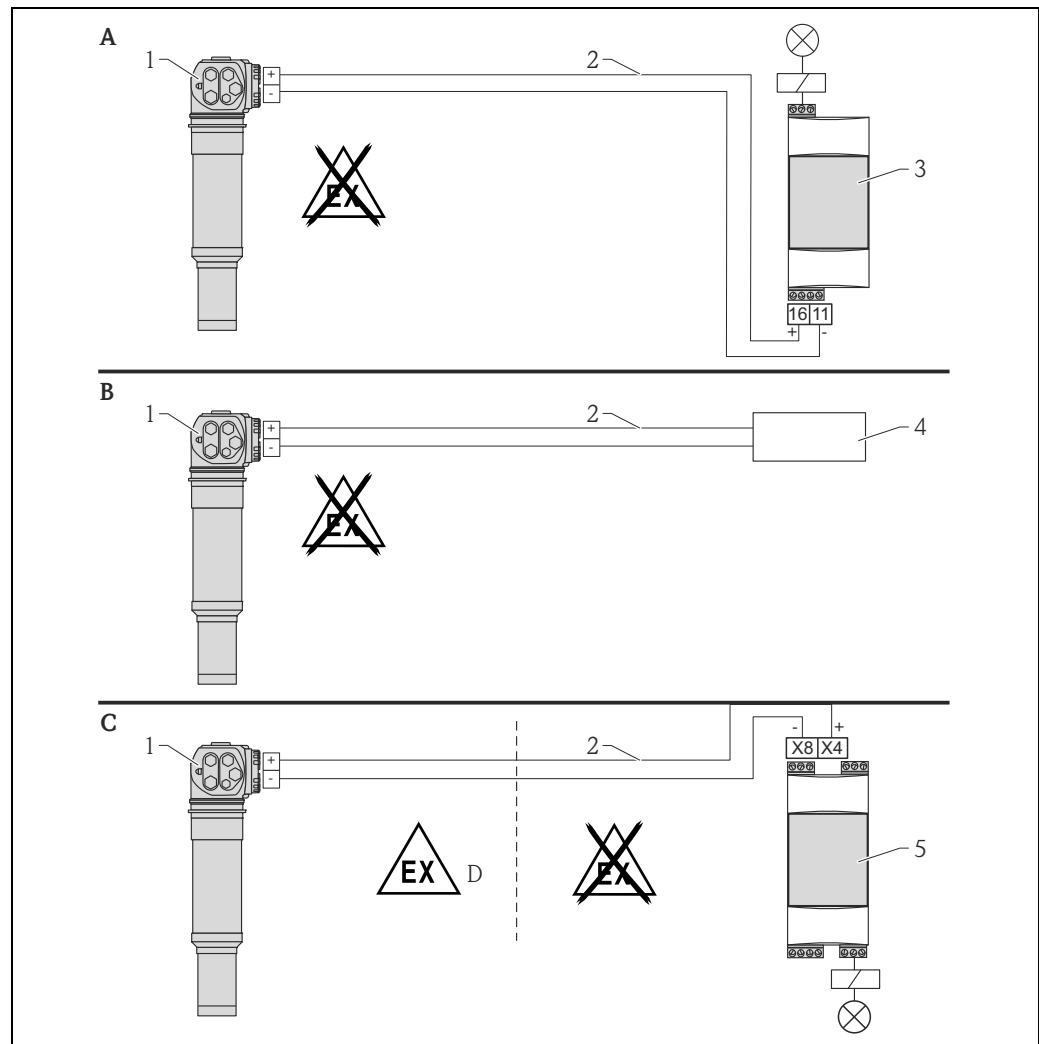

- | | | | |
|---|--|---|--------------|
| A | Wiring with RTA421 switching unit | 1 | Gammapilot M |
| B | Wiring with process control system | 2 | 4 to 20 mA |
| C | Wiring with RMA42 switching unit | 3 | RTA421 |
| D | When installing in hazardous areas, please observe the corresponding safety instructions | 4 | SPS |
| | | 5 | RMA42 |

Ex applications in connection with RMA42

Observe the following Safety Instructions:

- XA00303F/00/A3: ATEX II 2 (1) G for Gammapilot M
- XA00304F/00/A3: ATEX II 2 (1) D for Gammapilot M
- XA00095R/09/A3: ATEX II (1) G [Ex ia] IIC, ATEX II (1) D [Ex ia] IIIC for RMA42

SIL applications for Gammapilot M FMG60 in conjunction with RMA42 (for point level detection 200/400 mm PVT scintillator)

- The Gammapilot M meets SIL2/3 as per IEC 61508, see:
 - Functional safety manual SD00230F/00/EN (Maximum point level detection)
 - Functional safety manual SD00324F/00/EN (Minimum point level detection)
- The RMA42 meets SIL2 as per IEC 61508:2010 (Edition 2.0), see functional safety manual SD00025R/09/EN.

Density measurement

The measured values of up to nine samples of known density can be stored in the Gammapiilot M and used for the calibration of density measurements. From these calibration points, the Gammapiilot M calculates the absorption coefficient μ and the linearization curve automatically. These parameters are necessary to calculate the density from the pulse rate. In the case of a one point calibration a default value is used for the absorption coefficient μ (which can be changed manually).

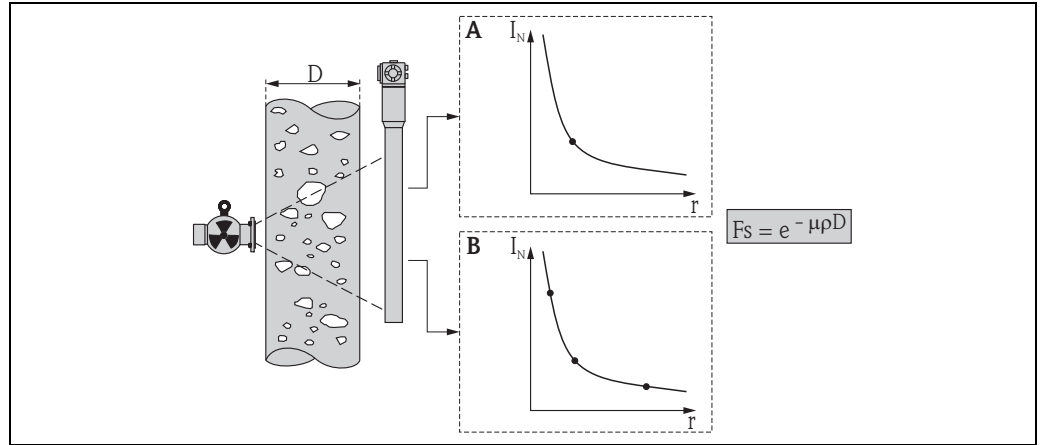

- A One point calibration
- B Multiple point calibration
- D Pipe diameter or irradiated measuring path
- I_N Pulse rate (counts per second)

- F_S Damping factor
- ρ Density
- μ Absorption coefficient

Concentration measurement

The Gammapiilot M determines the concentration indirectly via a density measurement. For this calculation a linearization table consisting of up to 32 value pairs "density - concentration" can be entered. In this way the solid content of a liquid can be measured for example (percentage of volume or weight).

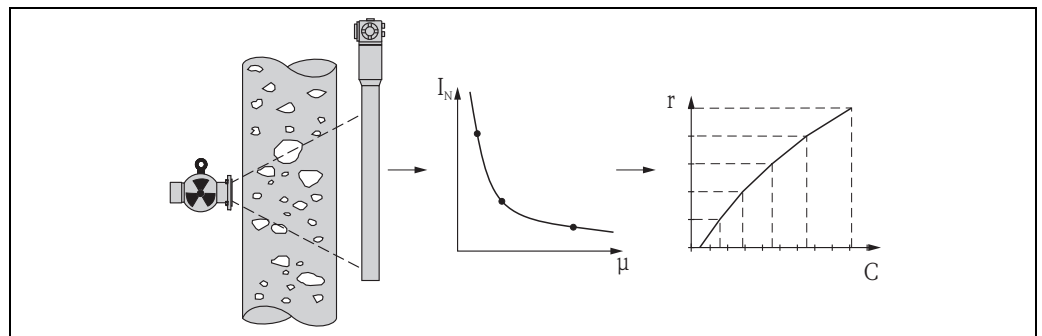

- I_N Pulse rate (counts per second)
- ρ Density
- C Concentration

General functions

Decay compensation

The automatic decay compensation of the Gammapiilot M compensates the decrease of activity caused by the radioactive decay. Accurate measurement is thus possible over the entire operating time of the gamma radiation source.

Gammagraphy detection

The Gammapiilot M has got a function which detects short-term interference radiation. This function indicates if the measurement is disturbed by non-destructive gammagraphic material-testings in the proximity of the measuring point.

Measuring solids flow

In conjunction with a density measuring device, such as Endress+Hauser's "Gammapilot M", Promag 55S also determines the rate of solids with regard to the mass, volume or percentage content.

The following order information is required for this purpose for Promag 55S:

Order option for software function "Solids flow" (F-CHIP) and order option for a current input.

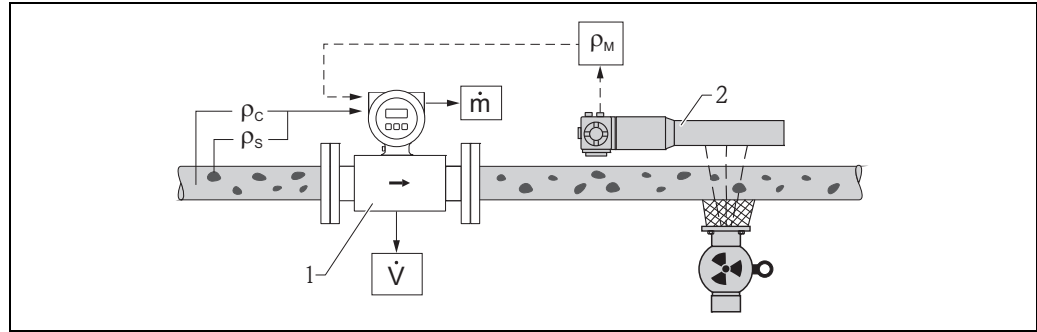

Solids flow measurement (\dot{m}) with the aid of a density and flow measuring device. If the density of the solids (ρ_s) and the density of the transporting liquid (ρ_c) are also known, the solids flow rate can be calculated.

- 1 Flow measuring device (Promag 55S) → Volume flow (\dot{V}). The solids density (ρ_s) and the density of the transporting liquid (ρ_c) also have to be entered in the transmitter
- 2 Density measuring device (e.g. "Gammapilot M") → Total density ρ_M (transporting liquid and solids)

System Integration

4 to 20mA with HART protocol

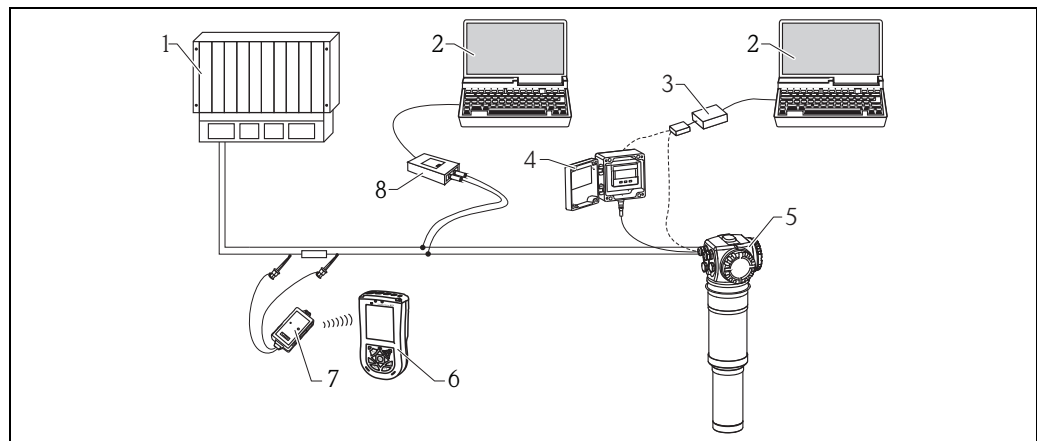

- | | | | |
|---|---|---|--|
| 1 | PLC (programmable logic controller) | 5 | Gammapilot M |
| 2 | Computer with operating tool (e.g. FieldCare) | 6 | Field Xpert SFX100 |
| 3 | Commubox FXA291 with ToF Adapter FXA291 | 7 | VIATOR Bluetooth modem with connection cable |
| 4 | FHX40 | 8 | Commubox FXA195 (USB) |

If the HART communication resistor is not built into the supply unit, it is necessary to insert a communication resistor of 250 Ω into the 2-wire line.

Operation via the service interface

- With the display and operating unit FHX40
- With a personal computer, Commubox FXA291 with ToF Adapter FXA291 (USB) and the operating program "FieldCare". FieldCare is a graphical operating software for devices from Endress+Hauser. It assists with commissioning, securing data, signal analysis and documentation of the measuring point.

Operation via HART

- With Fiel Xpert SFX100
- With the Commubox FXA195 and the operating program "FieldCare"

PROFIBUS PA

A maximum of 32 transmitters (8 if mounted in an explosion hazardous location Ex ia IIC according to the FISCO model) can be connected to the bus. The segment coupler (1) provides the operating voltage to the bus. For further information on the PROFIBUS-PA standard, refer to the Operating Instructions BA00034S/04/EN "PROFIBUS-DP/PA: Guidelines for planning and commissioning" or to the PROFIBUS-PA Specification EN 50170 (DIN 19245).

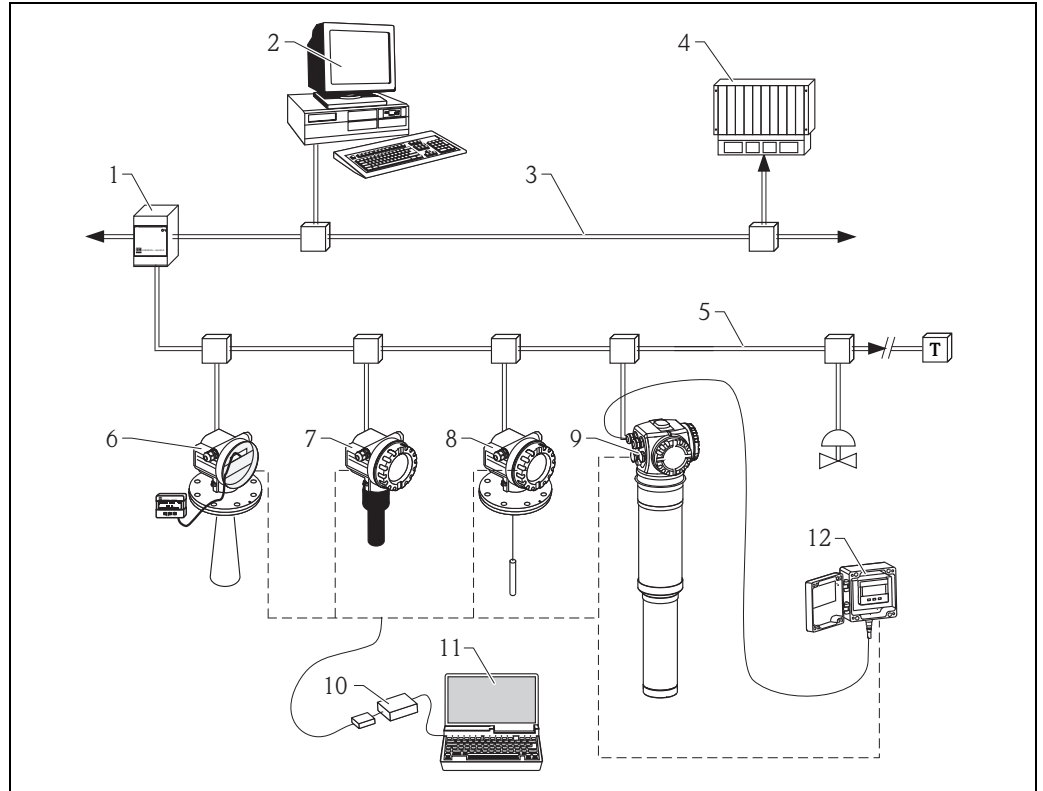

- | | | | |
|---|---------------------------------|----|---|
| 1 | Segment coupler | 7 | Prosonic M |
| 2 | Fieldcare, Profiboard/Proficard | 8 | Levelflex M |
| 3 | PROFIBUS DP | 9 | Gammapilot M |
| 4 | PLC | 10 | Commubox FXA291 with ToF Adapter FXA291 |
| 5 | PROFIBUS PA | 11 | Computer with operating tool (e.g. FieldCare) |
| 6 | Micropilot M with VU331 display | 12 | FHX40 with VU331 display |

Operation via the service interface

- With the display and operating unit FHX40
- With a personal computer, Commubox FXA291 with ToF Adapter FXA291 (USB) and the operating program "FieldCare". FieldCare is a graphical operating software for devices from Endress+Hauser. It assists with commissioning, securing data, signal analysis and documentation of the measuring point.

Operation via PROFIBUS

With Profiboard or Proficard and the operating program "FieldCare".

FOUNDATION Fieldbus (FF)

A maximum of 32 transmitters (standard or Ex d) can be connected to the bus. For explosion protection Ex ia: the maximum number of transmitters depends on the established rules and standards for interconnecting intrinsically safe circuits (EN 60079-14) with proof of intrinsic safety.

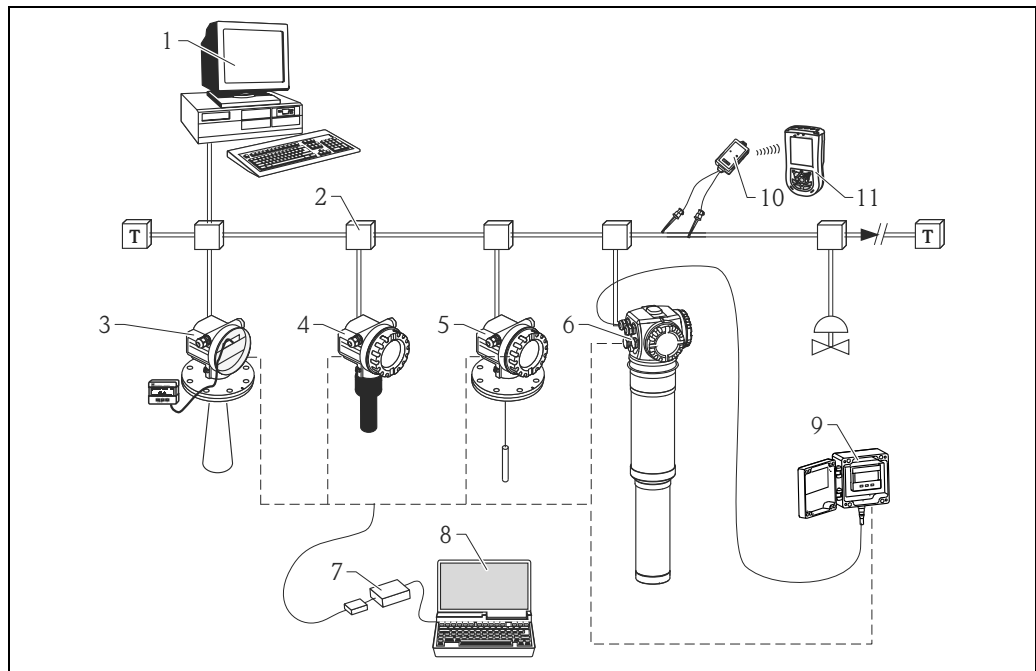

A0018251

1	Fieldcare, Profiboard/Proficard	7	Commubox FXA291 with ToF Adapter FXA291
2	FF link	8	Computer operating tool (e.g. FieldCare)
3	Micropilot M with VU331 display	9	FHX40 with operating modul VU331
4	Prosonic M	10	VIATOR Bluetooth modem with connection cable
5	Levelflex M	11	Field Xpert SFX100
6	Gammapilot M		

Operation via the service interface

- With the display and operating unit FHX40
- With a personal computer, Commubox FXA291 with ToF Adapter FXA291 (USB) and the operating program "FieldCare". FieldCare is a graphical operating software for devices from Endress+Hauser. It assists with commissioning, securing data, signal analysis and documentation of the measuring point.

Operation via FOUNDATION Fieldbus

- With Field Xpert SFX100
- With a configuration program, e.g. NI-FBUS Configurator.

Input

Measured variable

The Gammapilot M measures the pulse rate (number of counts per second). This rate is proportional to the intensity of radiation at the detector. From this rate, the Gammapilot M calculates the desired measured value:

- Level limit (0% = "radiation path free"; 100% = "radiation path covered")
- Level (in %)
- Position of interface (in %)
- Density (unit selectable)
- Concentration (unit selectable)

Pulse rate:

- Max. 45000 c/s per individual unit
- Max. 65000 c/s cascade

Sensitivity

The sensitivity determines, which pulse rate arises from a local dose rate of 1 $\mu\text{Sv/h}$. The sensitivity depends on the following parameters:

- Type of scintillator
- Measuring range
- Applied isotope

Scintillator	Measuring range [mm (in)]	Sensitivity for ^{137}Cs [(c/s)/($\mu\text{Sv/h}$)]	Sensitivity for ^{60}Co [(c/s)/($\mu\text{Sv/h}$)]
NaI	50 (1.97)	1250	350
PVT	200 (7.87)	2000	1000
	400 (15.7)	4000	2000
	800 (31.5)	8000	4000
	1200 (47.2)	12000	6000
	1600 (63)	16000	8000
	2000 (78.7)	20000	10000

Increasing the sensitivity by cascading

The sensitivity depends on the length of the detector. The sensitivity can be increased by connecting several sensors (cascading parallel mode). Only one transmitter - the "Master" - must be calibrated.

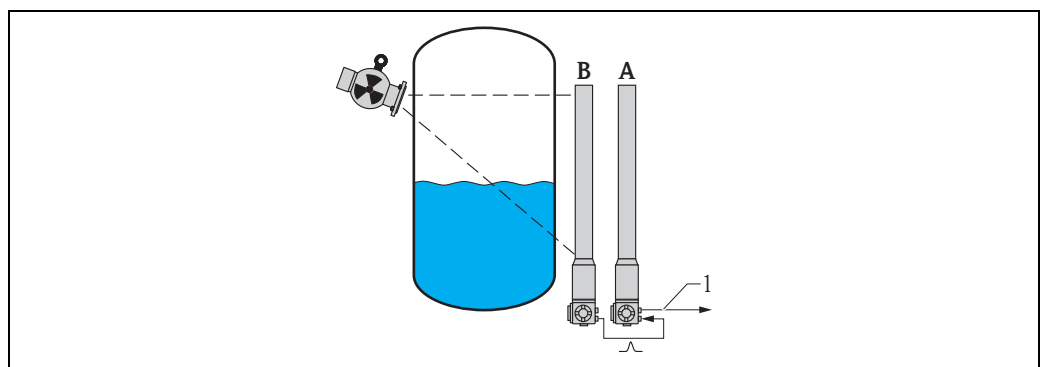

Double sensitivity achieved by cascading of two Gammapilot. They are assigned different roles:

- A Master
- B End-Slave
- 1 4 to 20 mA HART; PROFIBUS PA; FOUNDATION Fieldbus

Typical pulse rates

A radiometric measuring point should be designed in a way such that the following pulse rates are approximately obtained:

Level measurement (at empty vessel)

- 2500 c/s for ^{137}Cs
- 5000 c/s for ^{60}Co

Point level detection (at free radiation path)

- 1000 c/s for ^{137}Cs
- 2000 c/s for ^{60}Co

Density and concentration measurements

Depends on the application; contact the Endress+Hauser service or the "Gamma Project Team" (gamma@pcm.endress.com).

Necessary pulse rate for SIL applications

See functional safety manual:

- SD00230F/00/EN (for max. point level detection)
- SD00324F/00/EN (for min. point level detection)

NOTICE

Even if the pulse rate is higher or lower than the values specified, reliable measurement may be possible. In case of doubt contact the Endress+Hauser service or the "Gamma Project Team" (gamma@pcm.endress.com).

Measuring range**Level measurement**

The transmitters are available with a measuring range up to 2 m (6.6 ft). In order to enlarge the measuring range, an arbitrary number of transmitters can be connected in series (cascading mode). The first transmitter of the series is defined to be the "Master", the further transmitters the "Slaves". The last transmitter of the series is defined to be the "End-Slave". Only the "Master" must be calibrated.

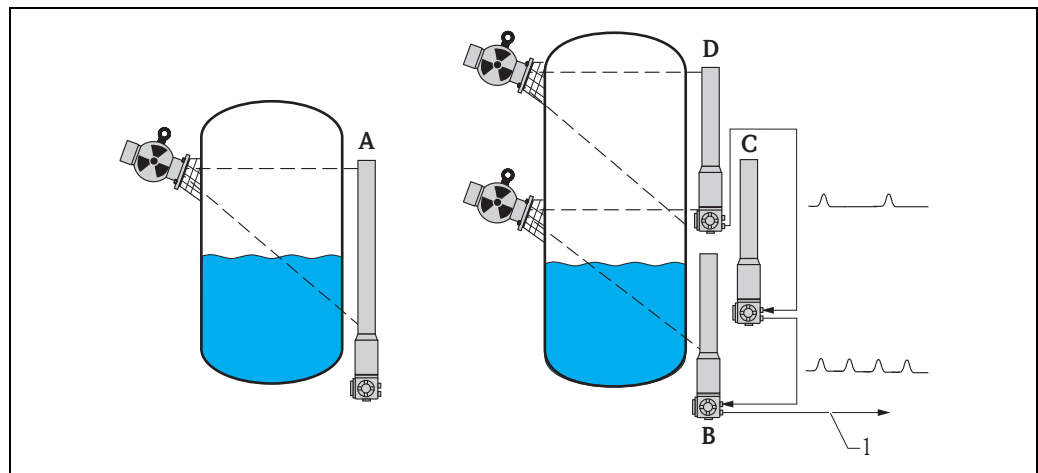

A0018107

- A One Gammapilot M is sufficient for measuring ranges up to 2 m (6.6 ft); For larger measuring ranges as many Gammapilot M as required can be connected (cascading mode). By Software settings they are defined as:
- B Master
- C Slave(s) or
- D End-Slave
- 1 4 to 20 mA HART; PROFIBUS PA; FOUNDATION Fieldbus

Max. point level detection

For point level detection the measuring range is nearly punctiform.
It is determined by the thickness of the scintillator (approx. 40 mm (1.57 in)).

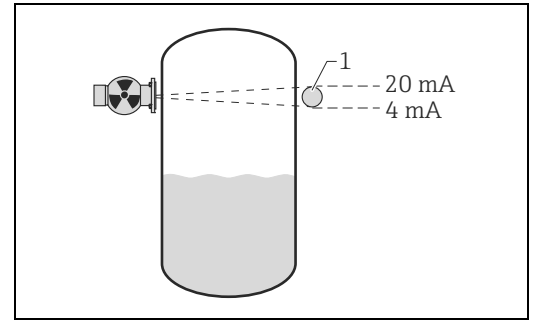

A0018253

1 Gammapilot M

Min. point level detection

For point level detection the measuring range is nearly punctiform.
It is determined by the thickness of the scintillator (approx. 40 mm (1.57 in)).

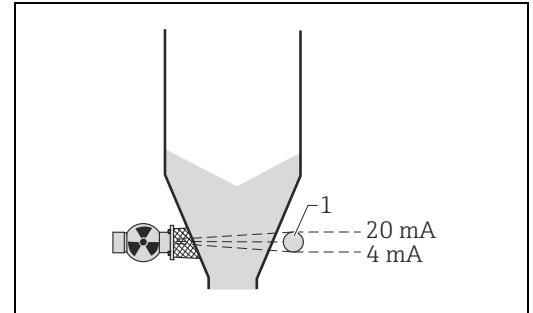

A0019922

1 Gammapilot M

Density measurement

For density measurements, the measuring range is determined by the user.

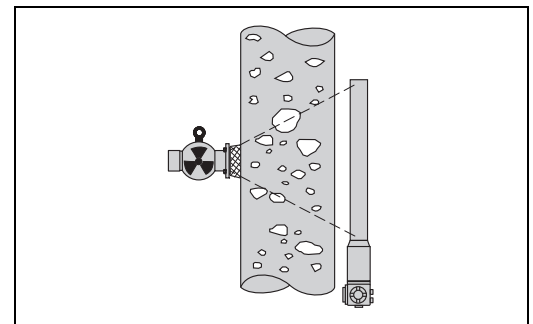

A0018254

Conditions/prerequisites for applications in safety-specific operation

See functional safety manual:

- SD00230F/00/EN (for max. point level detection)
- SD00324F/00/EN (for min. point level detection)

Temperature input (PT100) for density measurements

In order to compensate temperature influences on the density measurements a temperature sensor PT100 (4-wire connection) can be connected.

- Measuring range: -40 to +200 °C (-40 to +392 °F)
- Accuracy: ±1 K

Output

Output signal	<ul style="list-style-type: none"> ▪ 4 to 20 mA (active; invertible) with HART protocol, max. load 500 Ω ▪ PROFIBUS PA ▪ FOUNDATION Fieldbus (FF) ▪ Pulses for cascading mode <p>Non-intrinsically safe current output and bus interface guarantees additional galvanic isolation up to max. 253 V_{AC}.</p>
Error signal	<p>Errors occurring during commissioning or operation are signaled in the following way:</p> <ul style="list-style-type: none"> ▪ Error symbol, error code and error description on the display and operating module ▪ Current output, configurable ("output on alarm" (*20) function): <ul style="list-style-type: none"> – MAX, 110%, 22 mA – MIN, -10%, 3.6 mA – HOLD (the last value is held) – User-specific value
Load	<ul style="list-style-type: none"> ▪ Max. load: 500 Ω ▪ Minimum load for HART communication: 250 Ω
Output damping	Freely selectable, 1 to 999 s

Power supply

Supply voltage	<ul style="list-style-type: none"> ▪ 90 to 253 V_{AC}; 50/60 Hz ▪ 18 to 36 V_{DC}; protection against reversed polarity <p>The detector guarantees safe galvanic isolation up to max. 253 V_{AC} between the power supply circuit and all other detector circuits.</p> <p> For the following option models, the supply voltage for FM and CSA is restricted to 250 V_{AC}:</p> <ul style="list-style-type: none"> ▪ Feature 010 "Approval", option model N "CSA General Purpose" ▪ Feature 010 "Approval", option model P "CSA Cl. I Gr. A-D/Cl. II Gr. E-G/Cl. III, zone 1" ▪ Feature 010 "Approval", option model S "FM Cl. I Gr. A-D/Cl. II Gr. E-G/ Cl. III, Zone 1"
Power consumption	<ul style="list-style-type: none"> ▪ AC supply: approx. 8.5 VA ▪ DC supply: approx. 3.5 W
Overvoltage category	<p>II</p> <p>Power supply and signal output are galvanically isolated from one another.</p>
Protective class	1
Potential equalization	The device must be included into the local potential equalization system.

Electrical connection

Connection compartments

The Gammapilot M has got two terminal compartments:

- Terminal compartment A, for
 - Power supply
 - Signal output (depending on the instrument version)
- Terminal compartment B, for
 - Signal output (depending on the instrument version)
 - PT100 input (4-wire)
 - Pulse input for cascading mode
 - Pulse output for cascading mode
 - Display and operating module FHX40 (or VU331)

NOTICE

Depending on the instrument version, the signal output is located in the terminal compartment 1 or 2.

Maximum cable length:

- For cascade, 20 m (66 ft) each
- For PT100 2 m (6.6 ft) (temperature should be measured as close as possible to density measurement)

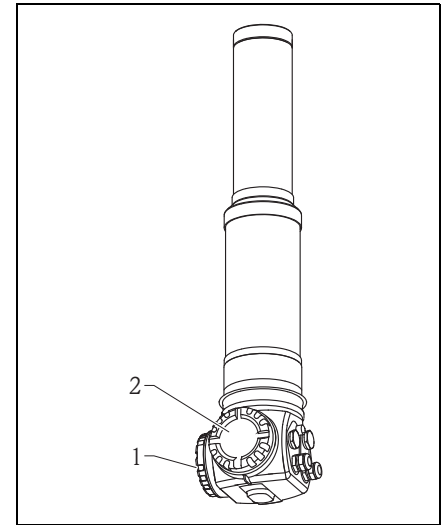

A0018082

Cable entries

The number and type of cable entries depend on the instrument version ordered. The following types may occur:

- Gland M20x1.5
tightening diameter (clamping range):
7.0 to 10.5 mm (0.28 to 0.41 in)
- Cable entry:
 - M20x1.5
 - G1/2
 - NPT1/2
- M12 connector ("Connector", → 19)
- 7/8" connector ("Connector", → 19)

In addition, Gammapilot M has a socket to connect the separate display and operating unit FHX40.

The housing of the Gammapilot M does not have to be opened to connect the FHX40.

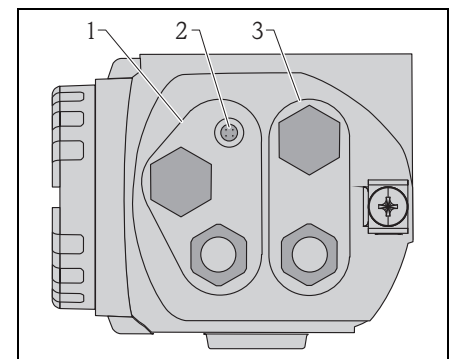

A0018083

- 1 Cable entries for terminal compartment 2
- 2 Socket for FHX40
- 3 Cable entries for terminal compartment 1

NOTICE

Cable entries

- ▶ On delivery, not more than one cable gland is present for each of the terminal compartments. If further cable glands are required (e.g. for cascading mode), they must be supplied by the user.
- ▶ Connecting cables should be routed away from the housing from below to prevent moisture from penetrating the connection compartment. Otherwise, a drain loop should be provided or the Gammapilot M should be fitted with a weather protection cover.

Potential equalisation

Before wiring, connect the potential matching line to the external ground terminal of the transmitter. If a water cooling jacket is present, it must be separately connected to the potential matching line.

CAUTION

In Ex applications, the instrument must only be grounded on the sensor side. Further safety instructions are given in the separate documentation for applications in explosion hazardous areas.

NOTICE

For optimum electromagnetic compatibility the potential matching line should be as short as possible and at least 2.5 mm² (14 AWG) in cross-section.

Terminal assignment

Terminal compartment 1

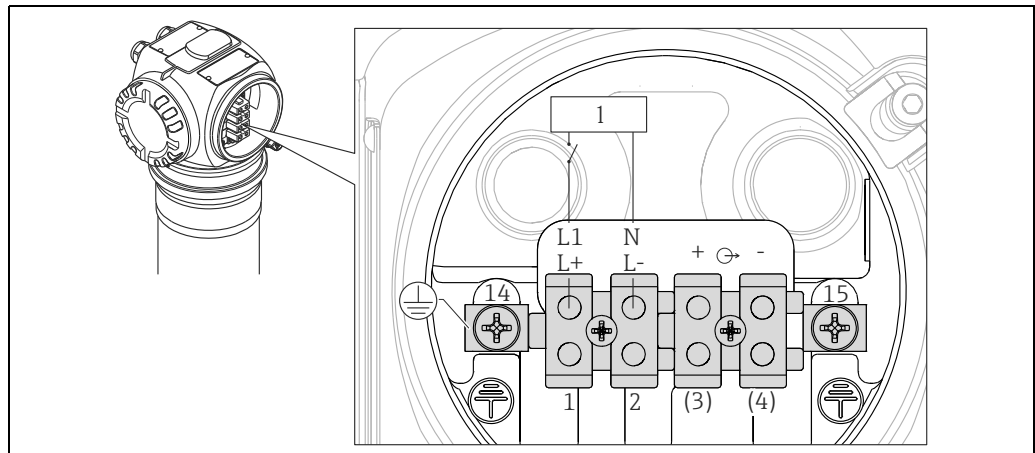

A0018084

1 90 to 253VAC, 18 to 36 VDC

Terminal compartment 2

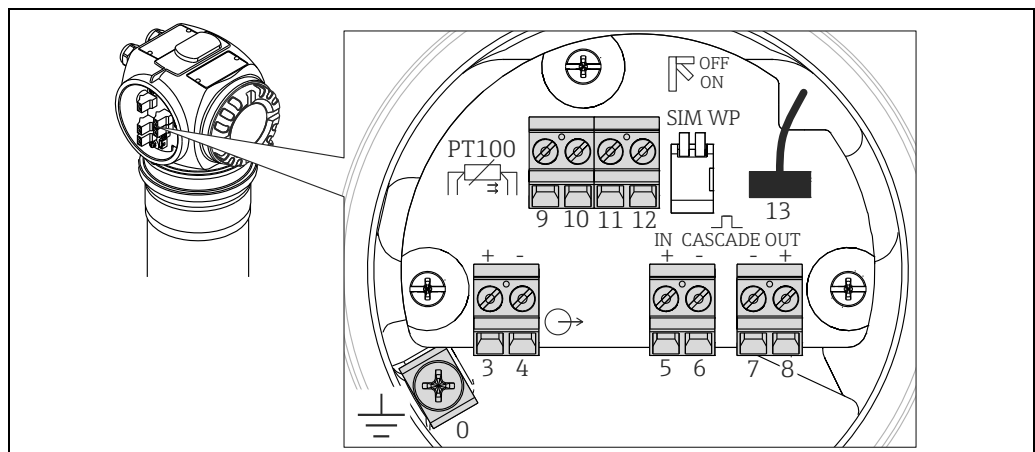

A0018085

Terminal(s)	Meaning
0	Grounding of the cable screen ¹⁾
1, 2	Power supply ²⁾
Compartment 2: 3, 4 Compartment 1: (3) ¹⁾ , (4) ¹⁾	<p>Signal output, depending on communication version:</p> <ul style="list-style-type: none"> ■ 4 to 20mA with HART ■ PROFIBUS PA ■ Foundation Fieldbus <p>(Depending on the device version ordered, the signal output is in connection compartment 1 or 2)</p> <p>NOTICE For the versions of the Gammapilot M with fieldbus plug connectors (M12 or 7/8"), the signal output is wired in compartment 2 on delivery and connected to the fieldbus plug connector. In this case, the housing needs not to be opened for connecting the signal line.</p>
5, 6	Pulse input (for cascading mode; is used for master and slave)
7, 8	Pulse output (for cascading mode; is used for slave and end slave)
9, 10, 11, 12	PT100 input (4-wire)
13	Plug for display and operating module VU331 (normally in FHX40); is wired on delivery and connected to the FHX40 plug
14	Protective earth ¹⁾
15	Protective earth or grounding of the cable screen ¹⁾

1) Rated cross section > 1 mm² (17 AWG)

2) Rated cross section max. 2.5 mm² (14 AWG)



The cables used at terminals 14 or 15 must at least have the same cross section as the cables at terminals 1 and 2.

Feature 30 of the ordering information: Power supply wiring/output wiring		Terminal compartment for		
		Supply voltage	Signal output	
A	Non-Ex; Non-Ex	1	2	
B	Ex e; Ex ia	1	2	
C	Ex e; Ex e	1	1	
D	Ex d (XP); Ex d (XP)	1	1	
E	Ex d (XP); Ex ia (IS)	1	2	
F	Dust-Ex; Dust-Ex	1	1	
G	Ex e, Dust-Ex; Ex e, Dust-Ex	1	1	
H	Ex d, Dust-Ex; Ex d, Dust-Ex	1	1	
J	Ex e, Dust-Ex; Ex ia, Dust-Ex	1	2	
K	Ex d, Dust-Ex; Ex ia, Dust-Ex	1	2	
L	Dust-Ex; Ex ia	1	2	

A0018082

Connector

For the versions with a connector M12 or 7/8", the housing does not have to be opened for connecting the signal line.

Pin assignment for M12 connector

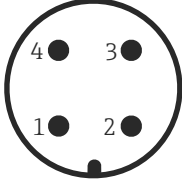
 <p style="text-align: right; font-size: small;">A0011175</p>	PIN	Meaning
	1	Signal +
	2	Not assigned
	3	Signal -
4	Earth	

Pin assignment for 7/8" connector

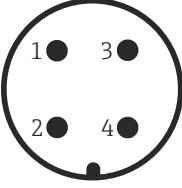
 <p style="text-align: right; font-size: small;">A0011176</p>	PIN	Meaning
	1	Signal -
	2	Signal +
	3	Shield
4	Not assigned	

Performance characteristics/Stability

Response time Dependent on the configuration; min. 2 s

Reference operating conditions

- Temperature: 20 °C ±10 °C (68 °F ±50 °F)
- Pressure: 1013 mbar ±20 mbar (15 psi ±0.29 psi)
- Humidity: not significant

Measured value resolution Depending on the measuring mode; up to 4 digits behind the decimal point

Influence of ambient temperature

Scintillator	Temperature range	Influence of ambient temperature
PVT	-40 to +60 °C (-40 to +140 °F)	±0.5%, typical long-term stability < 1%/a
NaI crystal	-40 to +60 °C (-40 to +140 °F)	±0.5%
	0 to +50 °C (32 to +122 °F)	±0.1%

Statistical fluctuation of the radioactive decay

The radioactive decay is subject to statistical fluctuations. Therefore, the pulse rate fluctuates about its average value. The standard deviation σ is a measure for these fluctuations. It can be calculated in the following way:

$$\sigma = \frac{\sqrt{I_N}}{\sqrt{\tau}}$$

The required parameters are:

- I_N : the pulse rate
- τ : the output damping (integration time) as defined by the user

The standard deviation can be used to calculate various confidence limits. For the planning of radiometric measuring points, the 2σ confidence limit is generally used. Approx. 95% of the indicated pulse rates have got a deviation of less than 2σ from the average value. Only for approx. 5% is the deviation larger than 2σ .

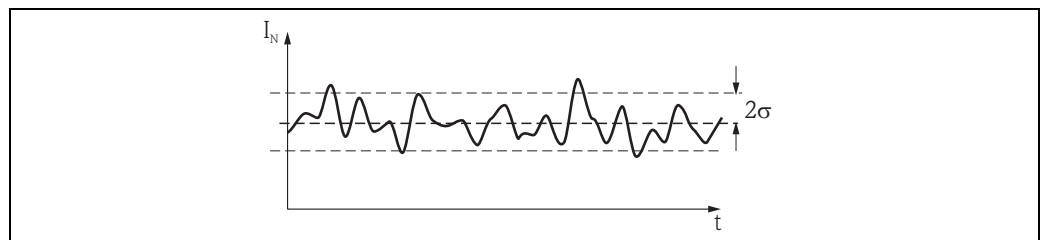

95% of the displayed measuring values are within the 2σ confidence limit.

In order to calculate the relative error (percentage), the standard deviation must be divided by the pulse rate:

$$2\sigma_{rel} = \frac{2\sigma}{I_N} = \frac{2}{\sqrt{I_N \tau}}$$

Example

- $I_N = 1000/s$
- $\tau = 10 s$

$$\text{▷ } 2\sigma_{rel} = 0.02 = 2\%$$

NOTICE

As a general rule, the statistical fluctuations can be reduced by enlarging the output damping (integration time).

Installation conditions

Installation conditions for level measurement

Conditions

- For level measurements the Gammapilot M is mounted vertically; if possible the detector head should point downwards.
- The exit angle of the source container must be exactly aligned to the measuring range of the Gammapilot M. Observe the measuring range marks of the Gammapilot M.
- In cascading mode no gap should occur between the measuring ranges of the different Gammapilot M.
- The source container and the Gammapilot M must be mounted as close to the vessel as possible. Any access to the beam must be blocked so that no persons or part of their body (hand, arm, head) may come into the area of the beam.
- In order to enlarge the lifetime, the Gammapilot M should be protected against direct sun. If necessary, a protective cover should be applied.
- The mounting device FHG60 ("Accessories", → 39) or an equivalent mounting device should be used for fastening the Gammapilot M. The mounting device must be installed in a way such that it can withstand the weight of the Gammapilot M³⁾ under all operating conditions (e.g. vibrations).

NOTICE

The Gammapilot M should be given additional support to prevent damage to the connecting cable or to the unit if it falls off.

Examples

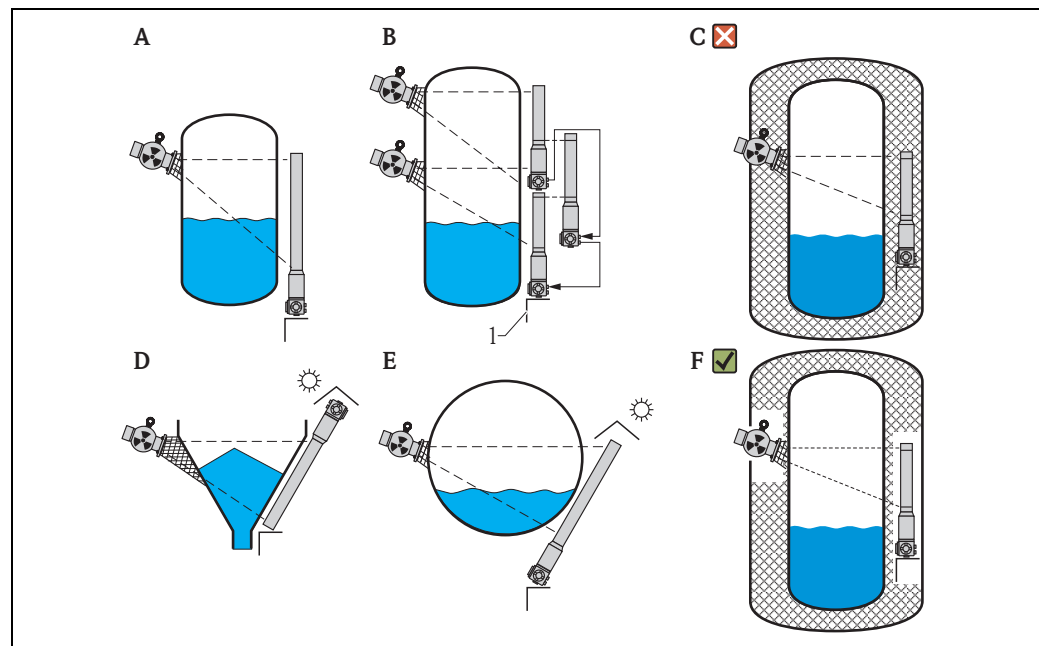

A0018074

- A Vertical cylinder; the Gammapilot M is mounted vertically with the detector head pointing downwards; the gamma ray is aligned to the measuring range.
- B Cascading of multiple Gammapilot M; there is no gap between the measuring ranges
- C Wrong: Gammapilot M mounted inside the tank insulation
- D Conical tank outlet (here with sun protection cover)
- E Horizontal cylinder (here with sun protection cover)
- F Right: Tank insulation removed for Gammapilot M

1 Support

3) The weights of the various versions of the Gammapilot M are summarized in the section "Dimensions/Weight".

Installation conditions for point level detection

Conditions

- For point level detection, the Gammapilot M should be mounted horizontally at the height of the desired level limit.
- The exit angle of the source container must be exactly aligned to the measuring range of the Gammapilot M. Observe the measuring range marks of the Gammapilot M.
- The source container and the Gammapilot M must be mounted as close to the vessel as possible. Any access to the beam must be blocked so that no persons or part of their body (hand, arm, head) may come into the area of the beam.
- In order to enlarge the lifetime, the Gammapilot M should be protected against direct sun. If necessary, a protective cover should be applied.
- The mounting device FHG60 ("Accessories", → 39) or an equivalent mounting device should be used for fastening the Gammapilot M. The mounting device itself must be fitted in a way such that it can withstand the weight of the Gammapilot M⁴⁾ under all operating conditions to be expected.

i More information with regard to the safety-related deployment of Gammapilot M can be found in Functional Safety Manual SD00230F/00/EN and SD00324F/00/EN.

Examples

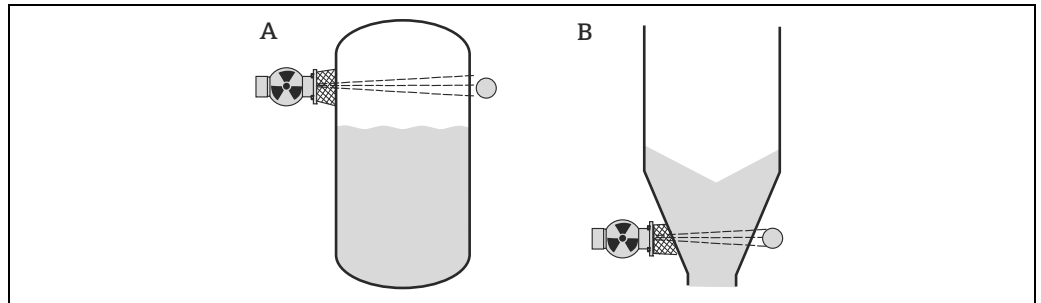

A Maximum fail-safe mode
 B Minimum point level detection

A0018075

4) The weights of the various versions of the Gammapilot M are summarized in the section "Dimensions/Weight".

Installation conditions for density and concentration measurement

Conditions

- If possible, density and concentration should be measured at vertical pipes with a feed direction from bottom to top.
- If only horizontal pipes are accessible, the path of the ray should also be arranged horizontally to reduce the influence of air bubbles and sediments.
- The Endress+Hauser clamping device ("Accessories", → 39) or an equivalent clamping device should be used for fastening the radiation source container and the Gammapilot M to the measuring tube. The clamping device itself must be installed in a way such that it can withstand the weight of the source container⁵⁾ and the Gammapilot M⁶⁾ under all operating conditions.
- The sample point may not be further than 20 m (66 ft) from the measuring point.
- The distance of the density measurement to
 - pipe bends is $\geq 3 \times$ pipe diameter
 - $\geq 10 \times$ pipe diameter for pumps

Configuration of the measuring system

The configuration of the source container and the Gammapilot M depends on the pipe diameter (or the length of the irradiated measuring path respectively) and the measuring range. These two parameters determine the measuring effect (relative change of the pulse rate). The measuring effect increases with the length of the radiation path through the medium. Therefore, diagonal irradiation or the use of a measurement section is necessary for small pipe diameters.

For the configuration of the measuring system please contact your Endress+Hauser sales organization or use the "Applicator"^{TM 7)} configuration software.

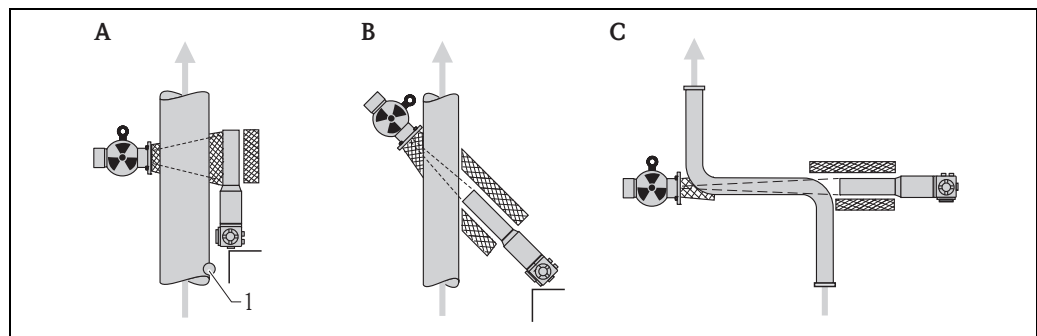

A Vertical beam (90°)
 B Diagonal beam (30°)
 C Measurement section

1 Sample point

NOTICE

General

- ▶ To increase the accuracy for density measurements, the use of a collimator is recommended. The collimator screens the detector against environmental radiation.
- ▶ When planning, the total weight of the measuring system must be taken into consideration.
- ▶ The Gammapilot M should be given additional support to secure it against falling or prevent damage to the connecting cable.
- ▶ A clamping device and a measurement section are available as accessories ("Accessories", → 39).

5) The weights of the source containers are specified in TI00435F/00/EN (FQG61, FQG62) and TI00346F/00/EN (QG2000).

6) The weights of the various versions of the Gammapilot M are summarized in the section "Dimensions/Weight".

7) The "Applicator"TM is available from your Endress+Hauser sales organization.

Empty pipe detection

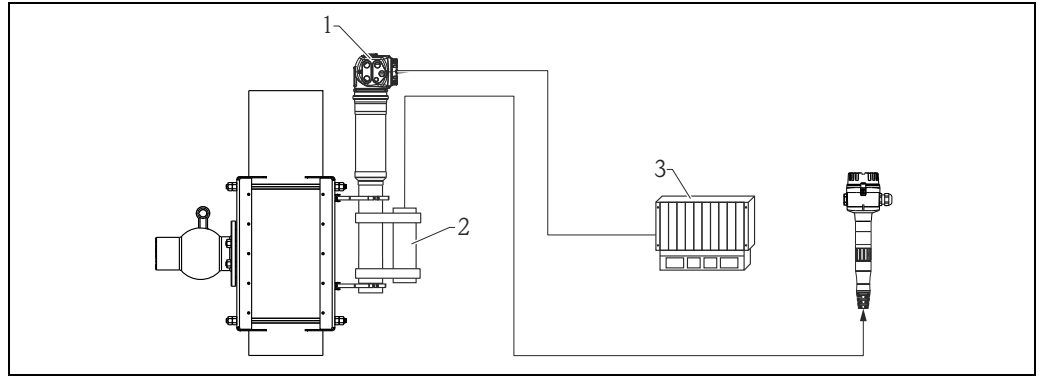

1 Gammapilot M
 2 Monitoring detector FTG20 or FMG60
 3 SPS

Mounting the FTG20 or FMG60 on the FMG60 for empty pipe detection

If the pipe becomes empty as a result of operational processes, the radiation on the detector side can hit dangerous levels.

- In such instances, the irradiation channel must be closed immediately for reasons of radiation protection.
- A high local dose rate also causes the detector unit (scintillator and photomultiplier) to age quickly.

The best way of avoiding such a situation is to mount a second radiometric measuring system that monitors the radiation intensity. If high radiation levels occur, an alarm is output and/or the source container is automatically switched off through pneumatic action for example.

Environment

Ambient temperature

Instrument version	Ambient temperature		Storage temperature
	without water cooling	with water cooling	
PVT Scintillator	-40 to +60 °C ¹⁾ (-40 to +140 °F)	0 to +120 °C ²⁾ (32 to +248 °F)	-40 to +50 °C (-40 to +122 °F)
NaI crystal	-40 to +60 °C (-40 to +140 °F)	0 to +120 °C ²⁾ (32 to +248 °F)	-40 to +60 °C (-40 to +140 °F)

- 1) If the ambient temperature permanently exceeds 40 to 45 °C (104 to 113 °F), water or air cooling is recommended.
- 2) Max. 75 °C (167 °F) at the compartment housing.

The temperature range may be restricted for applications in hazardous areas. Observe the specifications of the respective approval. Avoid exposure to direct sunlight; if necessary use a protective cover.

Climate class	DIN EN 60068-2-38 examination Z/AD
Installation height as per IEC 61010-1 Ed.3	2000 m (6600 ft)
Degree of protection	IP 66/67; TYPE 4/6
Vibration resistance	DIN EN 60068-2-64; Examination Fh; 10 to 2000 Hz, 1(m/s ²) ² /Hz
Shock resistance	DIN EN 60068-2-27; Examination Ea; 30 g, 18 ms, 3 shocks/direction/axis

Electromagnetic compatibility

- Interference emission to EN 61326, Equipment class B
- Interference immunity to EN 61326, Appendix A (Industrial) and NAMUR recommendation NE21

Water cooling

For the versions of the Gammapilot with water cooling jacket, the following applies:

- Material: 316L
- Water connection: 2 x G1/4"A, DIN ISO 228
- Inlet temperature: max. 40 °C (104 °F)
- Outlet temperature: max. 50 °C (122 °F) (temperature monitoring recommended)
- Water pressure: 4 to 6 bar (60 to 90 psi)

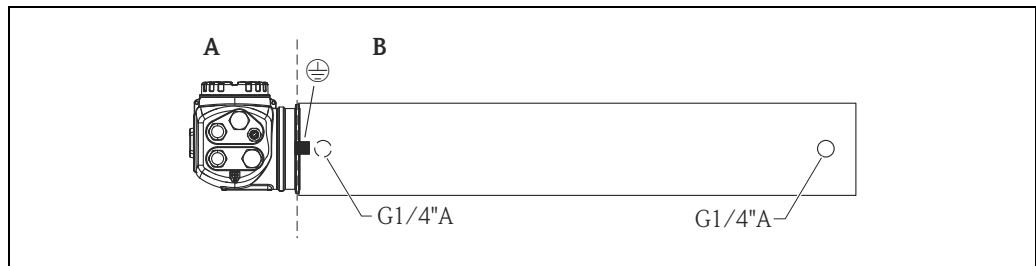

- A $T < 75\text{ °C}$ (167 °F)
- B $T < 120\text{ °C}$ (248 °F)

⚠ CAUTION

Detector or cooling jacket can be damaged if the cooling water freezes.

- ▶ Empty cooling jacket or protect against freezing.

⚠ WARNING

Pressurized water cooling system!

- ▶ Do not open the cylinder screws (see figure below) when pressurized.

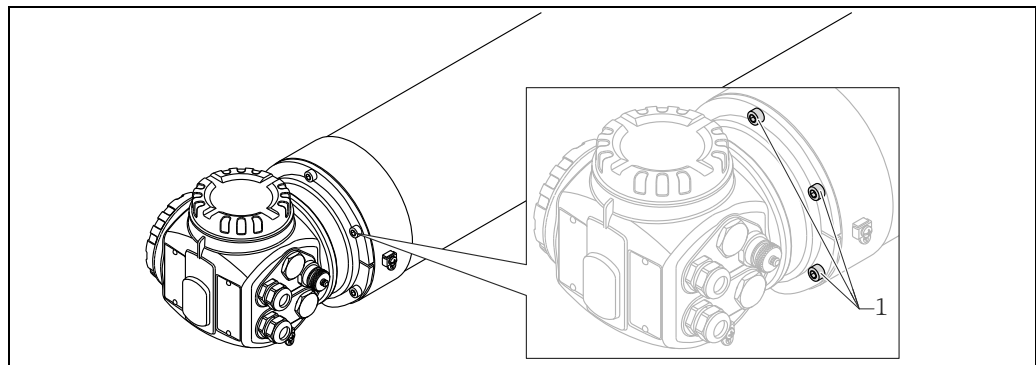

1 Cylinder screws

⚠ CAUTION

To consider when using water cooling jacket

- ▶ It is recommended to ground the water cooling jacket separately at the provided earth terminal (see picture above).
- ▶ The ambient temperature of the compartment housing must not exceed 75 °C (167 °F). This is also valid, if water cooling is applied.
- ▶ The three screws, connecting the pipe housing to the compartment housing, must **not** be opened.

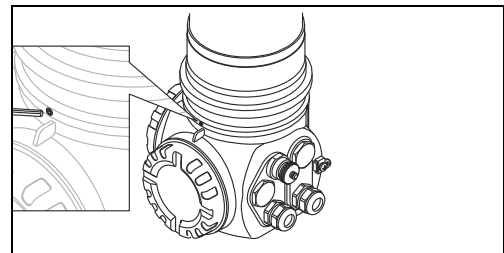

Mounting versions

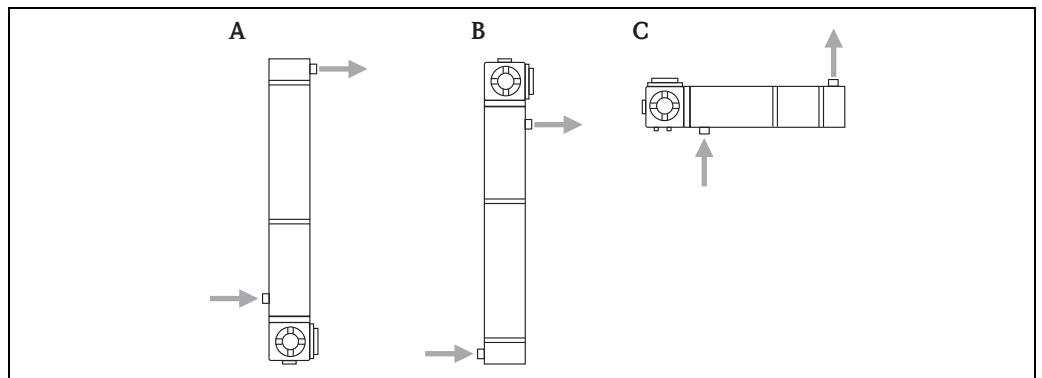

- A Recommended mounting position for level measurement: compartment housing at the bottom
- B In exceptional cases (e.g. shortage of space) the compartment housing may be located at the top
- C Mounting position for point level detection and density measurement

⚠ CAUTION

The water inlet must always be at the bottom to ensure that the water cooling jacket is completely filled.

Required flow rate

The required flow rate depends on:

- the ambient temperature at the water cooling jacket
- the inlet temperature
- the measuring range of the Gammapilot M

Typical values are given in the following tables:

Ambient temperature $T_A = 75\text{ °C}$ (167 °F)

Inlet temperature °C (°F)	Measuring range in mm (in)						
	50 (1.97)	200 (7.87)	400 (15.7)	800 (31.5)	1200 (47.2)	1600 (63)	2000 (78.7)
20 (68)	30 l/h	30 l/h	30 l/h	41 l/h	55 l/h	70 l/h	84 l/h
25 (77)	30 l/h	30 l/h	30 l/h	45 l/h	61 l/h	77 l/h	93 l/h
30 (86)	30 l/h	30 l/h	33 l/h	50 l/h	68 l/h	86 l/h	104 l/h
35 (95)	30 l/h	30 l/h	38 l/h	59 l/h	80 l/h	101 l/h	122 l/h
40 (104)	30 l/h	30 l/h	47 l/h	72 l/h	98 l/h	124 l/h	149 l/h

Ambient temperature $T_A = 100\text{ °C}$ (212 °F)

Inlet temperature °C (°F)	Measuring range in mm (in)						
	50 (1.97)	200 (7.87)	400 (15.7)	800 (31.5)	1200 (47.2)	1600 (63)	2000 (78.7)
20 (68)	30 l/h	30 l/h	38 l/h	59 l/h	80 l/h	101 l/h	122 l/h
25 (77)	30 l/h	30 l/h	42 l/h	64 l/h	87 l/h	110 l/h	133 l/h
30 (86)	30 l/h	30 l/h	47 l/h	73 l/h	98 l/h	124 l/h	150 l/h
35 (95)	30 l/h	30 l/h	54 l/h	84 l/h	113 l/h	143 l/h	173 l/h
40 (104)	33 l/h	33 l/h	66 l/h	101 l/h	137 l/h	173 l/h	210 l/h

Ambient temperature $T_A = 120\text{ °C}$ (248 °F)

Inlet temperature °C (°F)	Measuring range in mm (in)						
	50 (1.97)	200 (7.87)	400 (15.7)	800 (31.5)	1200 (47.2)	1600 (63)	2000 (78.7)
20 (68)	30 l/h	30 l/h	45 l/h	70 l/h	94 l/h	119 l/h	144 l/h
25 (77)	30 l/h	30 l/h	50 l/h	77 l/h	104 l/h	131 l/h	158 l/h
30 (86)	30 l/h	30 l/h	55 l/h	85 l/h	115 l/h	146 l/h	176 l/h
35 (95)	32 l/h	32 l/h	64 l/h	98 l/h	133 l/h	168 l/h	203 l/h
40 (104)	38 l/h	38 l/h	75 l/h	116 l/h	157 l/h	199 l/h	240 l/h

Collimator

Collimator

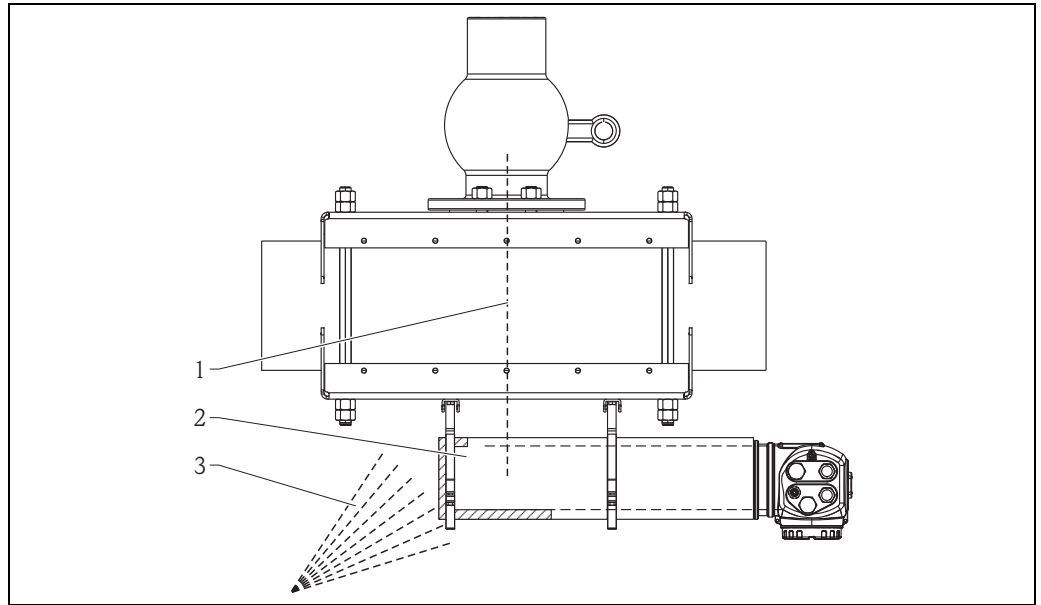

- 1 Radiation path
- 2 Collimator
- 3 Background radiation

The collimator is used to screen the detector from background radiation.
The collimators available are listed in the ordering information.

Process conditions

Process temperature

No limitations;
For high process temperatures sufficient isolation between process vessel and detector must be ensured ("Ambient temperature", → 25).

Process pressure

No limitations;
The influence of pressure must be taken into account when calculating the required activity and calibrating.

Mechanical construction

Dimensions, Weight

Gammapilot M (without water cooling jacket)

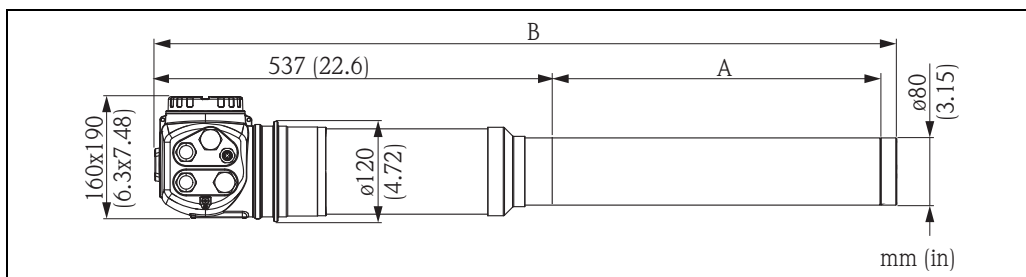

A0018072

Gammapilot M with water cooling jacket or collimator

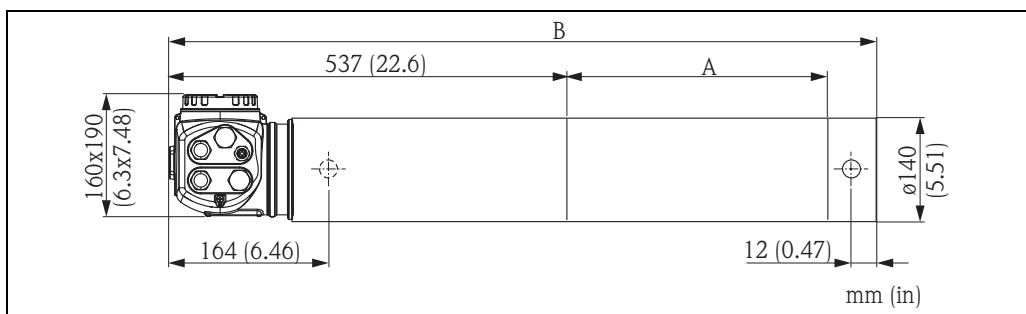

A0018073

Type	Measuring length A [mm (in)]	without water cooling jacket		with water cooling jacket		
		Overall length B [mm (in)]	Weight [kg (lbs)] ¹⁾	Overall length B [mm (in)]	Weight without water [kg (lbs)] ¹⁾	Weight including water [kg (lbs)] ¹⁾
NaI	50 (1.97)	621 (24.4)	14 (30.87)	631 (24.8)	18 (39.69)	20 (44.10)
NaI with collimator	50 (1.97)	663 (26.1)	35 (77.18)	-	-	-
PVT	200 (7.87)	780 (30.7)	15 (33.08)	790 (31.1)	20 (44.10)	24 (52.92)
PVT	400 (15.7)	980 (38.6)	16 (35.28)	990 (39)	23 (50.72)	29 (63.95)
PVT	800 (31.5)	1380 (54.3)	20 (44.10)	1390 (54.7)	31 (68.36)	40 (88.20)
PVT	1200 (47.5)	1780 (70.1)	24 (52.92)	1790 (70.5)	37 (81.59)	50 (110.25)
PVT	1600 (63)	2180 (85.8)	28 (61.74)	2190 (86.2)	45 (99.23)	61 (134.51)
PVT	2000 (7.87)	2580 (102)	31 (68.36)	2590 (102)	51 (112.46)	72 (158.76)

1) The given weight data are for 316L version. The weight of the aluminium version reduced by 5,3 kg (11.69 lbs).

Material

**Stainless steel and aluminum housing
(seawater-resistant*, powder-coated, corrosion-resistant)**

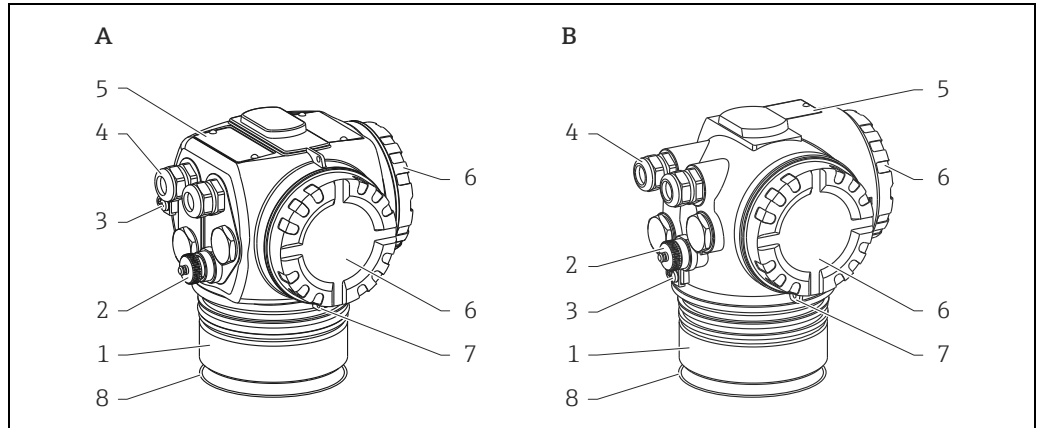

A Stainless steel housing
B Aluminium housing

Pos.	Part	Material
1	Stainless steel housing	316L (1.4404/1.4435)
	Aluminum housing	Aluminum (AlSi12) coated with RAL7035
2	FHX40 plug	316L (1.4435)
3	Ground terminal*	Screw: A2; Spring washer: A4; Clamp: 304 (1.4301); Holder: 1.4310
4	Adapter*	304 (1.4301)
	Cable gland	brass nickel-plated
	Plug	NPT1/2": 316L (1.4435); M20x1.5: 316L (1.4435); G½": 316L (1.4435)
	PA plug	brass nickel-plated
	FF plug	316L (1.4435)
	Sealing	EPDM-70 + PTFE
5	Nameplate*	304 (1.4301)
	Groove pin*	A2
6	Cover	316L (1.4435)
	Cover	Aluminum (AlSi12) coated with RAL7035
	Sealing	FKM70GLT
	Clamp	Screw: A4; Clamp: 316L (1.4581)
7	Tag*	304 (1.4301)
	Retaining ring for tag*	304 (1.4301)
8	Sealing ring	FKM70GLT

* Seawater-resistant on request (complete in 316L (1.4404)).

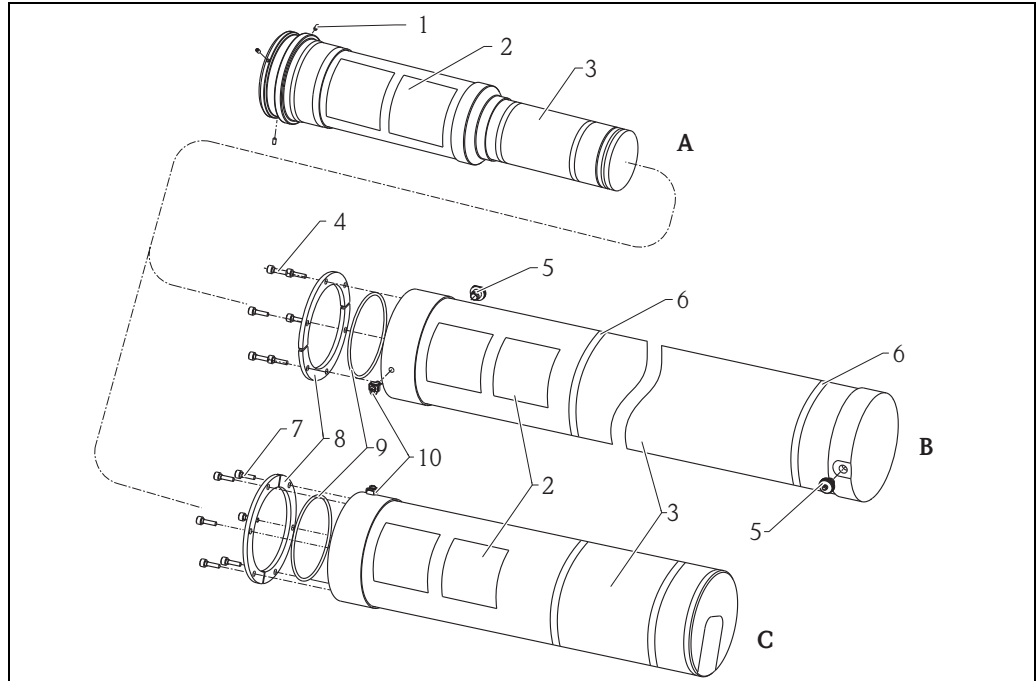

A0018265

- A Housing
- B Water cooling jacket
- C Collimator

Pos.	Part	Material
1	Setscrew	A4-70
2	Nameplate	Paper tag
3	Pipe housing / Cooling jacket	316L (1.4404/1.4435)
4	Screws*	A2-70
5	Plug G1/4"	PE-HD yellow
6	Measuring range tag	Aluminum, self-adhesive
7	Screws*	A2-70
8	Ring	316L (1.4404)
9	Sealing	FKM70GLT
10	Ground terminal*	Screw: A2; Spring washer: A4; Clamp: 304 (1.4301); Holder: 1.4310; Press bush: 316Ti (1.4571)

* Seawater-resistant on request (complete in 316L (1.4404)).

Human Interface

Display and operating unit FHX40

Connection

The separate display and operating unit FHX40 is available as an accessory. It is connected via the supplied cable (20 m (66 ft)) and plug to the Gammapilot M. It contains the display and operating module VU331.

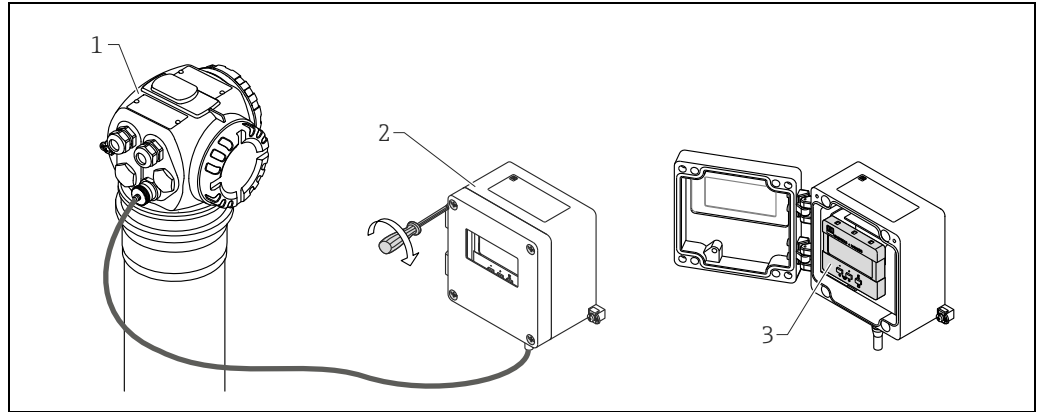

- 1 Gammapilot M
- 2 FHX40
- 3 Operating module VU331

A0018096

Operation

Operation takes place with the 3 keys of the display and operating module VU331. All device functions can be set through a menu system. The menu consists of function groups and functions. Within a function, application parameters can be read or adjusted. Via the plain text display, the user is guided through a complete configuration procedure.

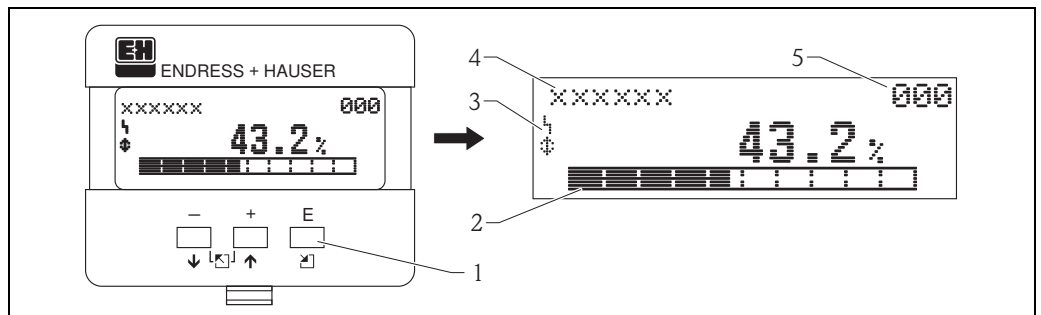

- 1 Operating keys
- 2 Bargraph
- 3 Symbols
- 4 Function name
- 5 Parameter identification number

A0018097

Display and operation can take place in one of seven languages:

- English
- German
- French
- Italian
- Dutch
- Spanish
- Japanese

Remote operation

Operation via Field Xpert SFX100

Field Xpert is an industrial PDA with integrated 3.5" touchscreen from Endress+Hauser on Windows Mobile. It offers wireless communication via the optional VIATOR Bluetooth modem as a point-to-point connection to a HART device, or via WIFI and Endress+Hauser Fieldgate FXA520 to offer communication to one or more HART devices. Field Xpert also works as a stand-alone device for asset management applications. For details, refer to BA00060S/04/EN.

Operation with FieldCare

FieldCare is an Endress+Hauser asset management tool based on FDT technology. With FieldCare, you can configure all Endress+Hauser devices as well as devices from other manufacturers that support the FDT standard. Hardware and software requirements you can find on the internet:

www.endress.com → select your country → search: FieldCare → FieldCare → Technical Data.

FieldCare supports the following functions:

- Configuration of transmitters in online operation
- Loading and saving device data (upload/download)
- Documentation of the measuring point

Connection options:

- HART via Commubox FXA195 and the USB port of a computer
- PROFIBUS PA via segment coupler and PROFIBUS interface card
- Commubox FXA291 with ToF Adapter FXA291 (USB) via service interface

NI-FBUS Configurator (only Foundation Fieldbus)

The NI-FBUS Configurator is an easy-to-use graphical environment for creating linkages, loops, and a schedule based on the fieldbus concepts. You can use the NI-FBUS Configurator to configure a fieldbus network as follows:

- Set block and device tags
- Set device addresses
- Create and edit function block control strategies (function block applications)
- Configure vendor-defined function and transducer blocks
- Create and edit schedules
- Read and write to function block control strategies (function block applications)
- Invoke Device Description (DD) methods
- Display DD menus
- Download a configuration
- Verify a configuration and compare it to a saved configuration
- Monitor a downloaded configuration
- Replace devices
- Save and print a configuration

Certificates and Approvals

Safety Manual (SIL 2/3)

SIL 2/3 in accordance with IEC 61508 see:

- SD00230F/00/EN "Functional Safety Manual" (for max. point level detection)
- SD00324F/00/EN "Functional Safety Manual" (for min. point level detection).

NOTICE

When using the Gammapilot M for min. point level detection, an additional reference radiation source contained in a FQG60 source container must be mounted to the detector tube.

- Isotope: ^{137}Cs
- Activity: 0.74 MBq (0.02 mCi)

For further information refer to:

- Brief operating instructions for mounting of FQG60 as a reference radiation source (KA00296F)

Ex approval

The available certificates are listed in the ordering information.
Observe the related safety instructions (XA) and Control Drawings (ZD).

External standards and guidelines

- **IEC 60529**
Protection class of housing (IP code)
- **IEC 61010**
Safety requirements for electrical equipment for measurement, control and laboratory use
- **IEC 61326**
Interference emission (Class B equipment), interference immunity (Annex A – Industrial area)
- **IEC 61508**
Functional safety of safety-related electric/electronic/programmable electronic systems
- **NAMUR**
Standards committee for measurement and control in the chemical industry

Certificates



Allocation to the option, see "Ordering information"

General

Approval Feature 010	Type of protection/level of protection	Power supply wiring/ Output wiring Option 030	Output (Communication) Option 040	Approval number
A	Non-hazardous area	A	1, 2, 3	—
F	Non-hazardous area, WHG	A	1	—
N	CSA General Purpose	A	1, 2, 3	—

Approval number: NEPSI GYJ101145

Approval Feature 010	Type of protection/level of protection	Power supply wiring/ Output wiring Option 030	Output (Communication) Option 040	Approval number
C	Ex de [ia] IIC T6	C	1	XA00536F
		C	2, 3	XA00537F
		B	1	XA00536F
		B	2, 3	XA00537F
D	Ex d [ia] IIC T6	D	1	XA00536F
		D	2, 3	XA00537F
		E	1	XA00536F
		E	2, 3	XA00537F

Approval number: IECEx BKI 05.0001

Approval Feature 010	Type of protection/level of protection	Power supply wiring/ Output wiring Option 030	Output (Communication) Option 040	Approval number
G	Ex de [ia Ga] IIC T6 Gb	B	1	XA00449F
		B	2, 3	XA00450F
		C	1	XA00449F
		C	2, 3	XA00451F
H	Ex d [ia Ga] IIC T6 Gb	E	1	XA00449F
		E	2, 3	XA00450F
		D	1	XA00449F
		D	2, 3	XA00451F

Approval number: KEMA 04 ATEX 1153

Approval Feature 010	Type of protection/level of protection	Power supply wiring/ Output wiring Option 030	Output (Communication) Option 040	Approval number
1	II 2(1) G Ex de [ia Ga] IIC T6 Gb	B	1	XA00303F
		B	2, 3	XA00332F
		C	1	XA00303F
		C	2, 3	XA00334F
2	II 2(1) G Ex de [ia Ga] IIC T6 Gb, WHG	B	1	XA00303F
		C	1	XA00303F
3	II 2(1) G Ex d [ia Ga] IIC T6 Gb	E	1	XA00303F
		E	2, 3	XA00332F
		D	1	XA00303F
		D	2, 3	XA00334F
4	II 2(1) G Ex d [ia Ga] IIC T6 Gb, WHG	E	1	XA00303F
		D	1	XA00303F
5	II 2(1) D Ex tb [ia Da] IIIC T80°C Db	F	1	XA00304F
		F	2, 3	XA00335F
		L	1	XA00304F
		L	2, 3	XA00333F
6	II 2(1) G Ex de [ia Ga] IIC T6 Gb II 2(1) D Ex tb [ia Da] IIIC T80°C Db	J	1	XA00303F XA00304F
		J	2, 3	XA00332F XA00333F
		G	1	XA00303F XA00304F
		G	2, 3	XA00334F XA00335F
7	II 2(1) Ex de [ia Ga] IIC T6 Gb, WHG II 2(1) D Ex tb [ia Da] IIIC T80°C Db, WHG	J	1	XA00303F XA00304F
		G	1	XA00303F XA00304F
8	II 2(1) G Ex d [ia Ga] IIC T6 Gb II 2(1) D Ex tb [ia Da] IIIC T80°C Db	K	1	XA00303F XA00304F
		K	2, 3	XA00332F XA00304F
		H	1	XA00303F XA00304F
		H	2, 3	XA00334F XA00335F
M	II 2(1) G Ex d [ia Ga] IIC T6 Gb, WHG II 2(1) D Ex tb [ia Da] IIIC T80°C Db, WHG	K	1	XA00303F XA00304F
		H	1	XA00303F XA00304F

Approval number: ID 3022785

Approval Feature 010	Type of protection/level of protection	Power supply wiring/ Output wiring Option 030	Output (Communication) Option 040	Approval number
S	FM Cl. 1 Gp. A-D, Cl. II Gp. E-G, Cl. III, Cl. I Zone 1 Ex d [ia] IIC t6	D	1	XA01100F
		D	2, 3	XA01108F
		E	1	XA01102F
		E	2, 3	XA01109F

Approval number: CSA 1653884

Approval Feature 010	Type of protection/level of protection	Power supply wiring/ Output wiring Option 030	Output (Communication) Option 040	Approval number
P	CSA Cl. I Gp. A-D, Cl. II Gp. E-G, Cl. III, Cl. I Zone 1 Ex d [ia] IIC T6	D	1	XA01099F
		D	2, 3	XA01110F
		E	1	XA01101F
		E	2, 3	XA01111F

Approval number: TC17525, TC19557 (NaJ-Scintillator)

Approval Feature 010	Type of protection/level of protection	Power supply wiring/ Output wiring Option 030	Output (Communication) Option 040	Approval number
K	TIIS Ex d [ia] IIC T6	D	1	BA00236F

Approval number: TC17524, TC19556 (PVT-Scintillator)

Approval Feature 010	Type of protection/level of protection	Power supply wiring/ Output wiring Option 030	Output (Communication) Option 040	Approval number
K	TIIS Ex d [ia] IIC T6	D	1	BA00236F

CE mark

The measuring system meets the legal requirements of the EC-guidelines. Endress+Hauser confirms the instrument passing the required tests by attaching the CE-mark.

GOST

Approval for GOST available.

Overfill protection

- WHG for point level detection
- SIL 2/3 in accordance with IEC 61508 see:
 - SD00230F/00/EN "Functional Safety Manual" (for max. point level detection)
 - SD00324F/00/EN "Functional Safety Manual" (for min. point level detection)

Ordering information

Ordering information

Detailed ordering information is available as follows:

- In the Product Configurator on the Endress+Hauser website: www.endress.com → Select country → Instruments → Select device → Product page function: Configure this product
- From your Endress+Hauser sales center: www.endress.com/worldwide



Product Configurator - the tool for individual product configuration

- Configuration data updated on a daily basis
- Depending on the device: Direct input of data specific to measuring point, such as measuring range or operating language
- Automatic verification of exclusion criteria
- Automatic generation of order code with breakdown in PDF or Excel output format
- Possibility to order directly from the Endress+Hauser online shop

Accessories

Commubox FXA195 HART

For intrinsically safe HART communication with FieldCare via the USB port. For details, see TI00404F/00/EN.

Commubox FXA291

The Commubox FXA291 connects Endress+Hauser field devices with a CDI interface (= Endress+Hauser Common Data Interface) and the USB port of a computer or laptop. For details, see TI00405C/07/EN.

NOTICE

For Gammapilot M, you also need the "ToF adapter FXA291" accessory.

ToF Adapter FXA291

The ToF Adapter FXA291 connects the Commubox FXA291 with the Gammapilot M by means of the USB port of a computer or laptop. For details, see KA00271F/00/A2.

Field Xpert SFX100

Compact, flexible and robust industry handheld terminal for remote parametrization and measured value inspection via the HART current output or FOUNDATION Fieldbus. For details refer to Operating Instructions BA00060S/04/EN.

Remote display FHX40

Dimensions

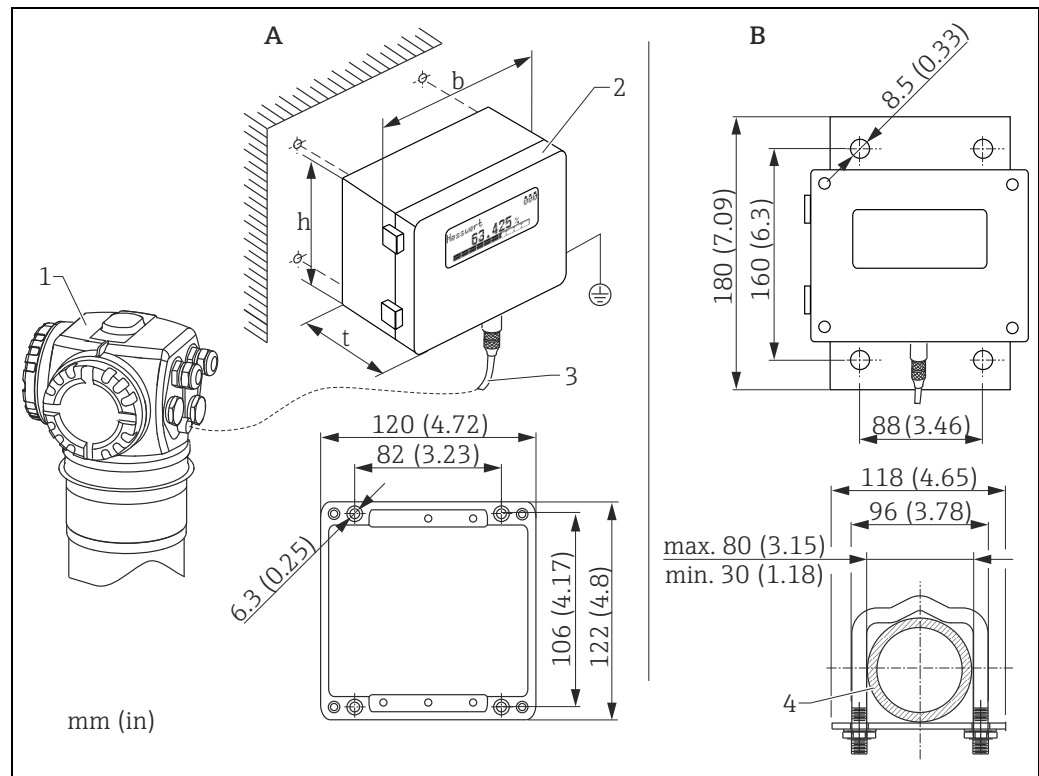

- A Wall-mounting (without mounting bracket)
- B Pipe-mounting (mounting bracket and plate supplied optionally)

- 1 Gammapilot M
- 2 Separat housing FHX40
- 3 Cable
- 4 Pipe

Ordering information

010 Approval	
A	Non-hazardous area
2	ATEX II 2G Ex ia IIC T6
3	ATEX II 2D Ex ia IIIC T80°C
H	ATEX II 3G Ex ic IIC T6, T5 Gc (in preparation)
G	IECEX zone1 Ex ia IIC T6/T5
S	FM IS Cl.I Div.1 Gr.A-D, zone 0
U	CSA IS Cl.I Div.1 Gr.A-D, zone 0
N	CSA General Purpose
K	TIIS Ex ia IIC T6
C	NEPSI Ex ia IIC T6/T5 Gb
Y	Special version, TSP-no. to be spec.
020 Cable	
1	20m/65ft (> HART)
5	20m/65ft (> PROFIBUS PA/FOUNDATION Fieldbus)
9	Special version, TSP-no. to be spec.
030 Additional Option	
A	Basic version
B	Mounting bracket, pipe 1" 2"
Y	Special version, TSP-no. to be spec.
995 Marking	
1	Tagging (TAG), see additional spec.

Use the cables provided for the corresponding communication version of the device to connect the remote display FHX40.

Technical data (cable and housing)

Max. cable length	20 m (66 ft) (fixed length including the cast-on plugs)
Temperature range	Temperature class T5: -40 to +75 °C (-40 to +167 °F) Temperature class T6: -40 to +60 °C (-40 to +140 °F)
Degree of protection	IP66/67 (housing); IP68 (cable) acc. to IEC 60529
Materials	Housing: AlSi12; cable glands: nickle plated brass
Dimensions [mm (in)]	122x150x80 (4.72x5.91x3.15) / HxWxD

Materials

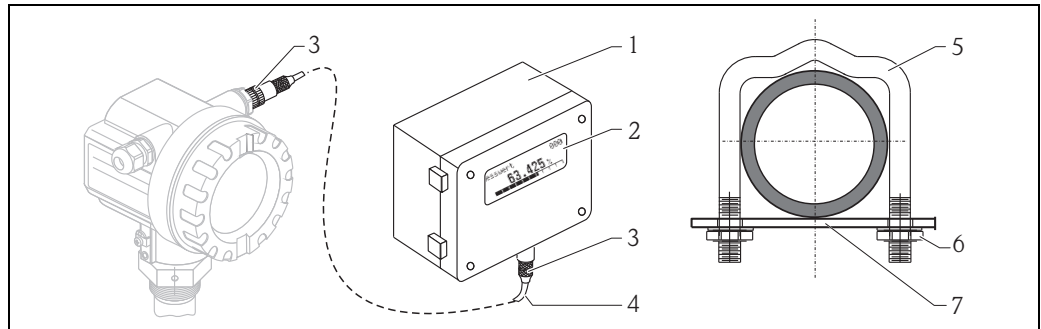

A0019282

Position	Part	Material
1	Housing/Cover	AlSi12, Screw: V2A
	Ground terminal	CuZn nickel-plated, Screw: V2A
2	Display	Glass
3	Cable gland	CuZn nickel-plated
4	Cable	PVC
5	Mounting bracket	316 Ti (1.4571) or 316 L (1.4435) or 316 (1.4401)
6	Nut	V4A
7	Plate Screw set (M5)	316 Ti (1.4571) Spring washer: 301 (1.4310) or V2A Screw: V4A, Nut: V4A

**Mounting device FHG60
(for level measurement and
level limit measurement)**

Dimensions

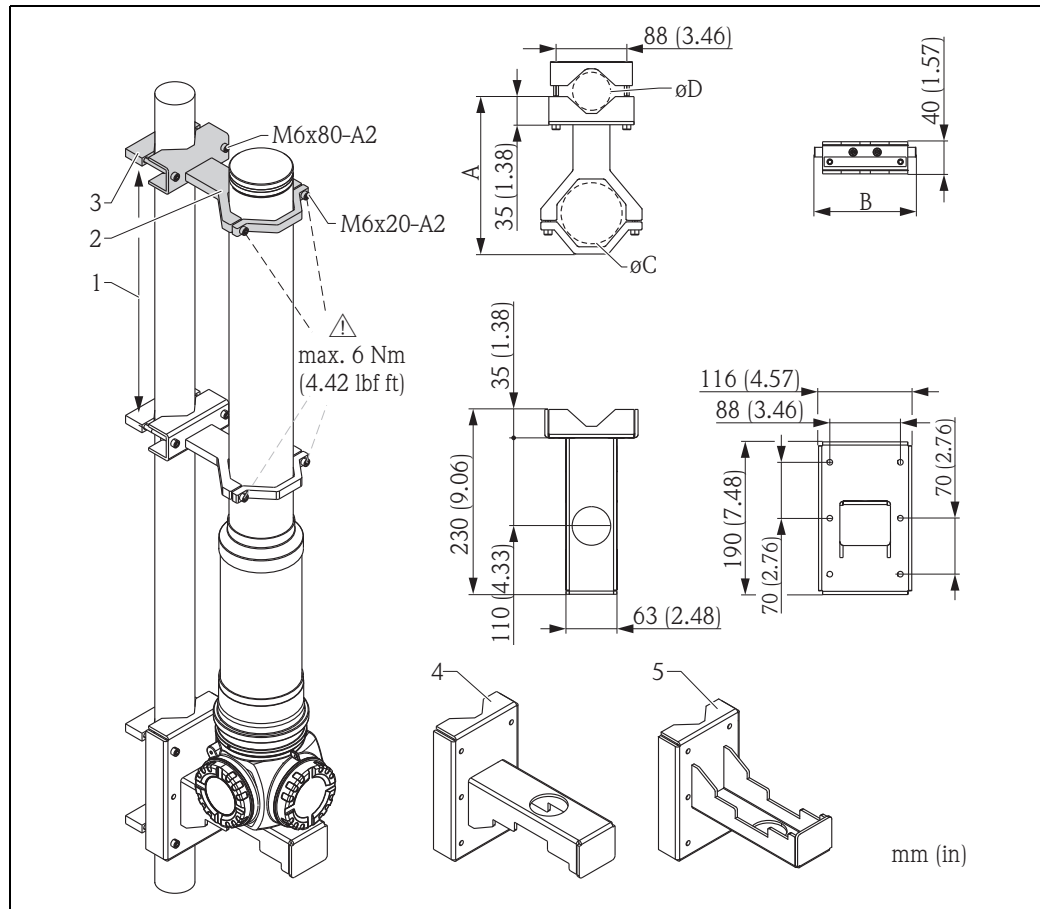

A0018139

- 1 Spacing as large as possible
- 2 Retainers (number and size depending on selected application⁸⁾; Allen screws to ISO 4762 are supplied)
- 3 Mounting clamps (number depending on selected application⁸⁾)
- 4 with preferred mounting method "housing head down" - bracket (for "level" application only⁸⁾)
- 5 with alternative mounting method "housing head up" - bracket (for "level" application only⁸⁾)

Size of the retainers (depending on the selected application):

Mounting position at the FMG60	A [mm (in)]	B [mm (in)]	øC [mm (in)]	øD [mm (in)]	Mounting
Scintillator pipe dimensions	196 (7.72)	126 (4.96)	80 (3.15)	40 to 65 (1.57 to 2.56)	(a)
Electronic pipe dimensions	210 (8.27)	150 (5.91)	102 (4.02)		(b)
Water cooling jacket dimensions	230 (9.06)	200 (7.87)	140 (5.51)		(c)

⚠ CAUTION

Max. torque for the screws of the retainers: 6 Nm (4.42 lbf ft).

8) See "Use" and "Ordering information for complete mounting set".

Application hints

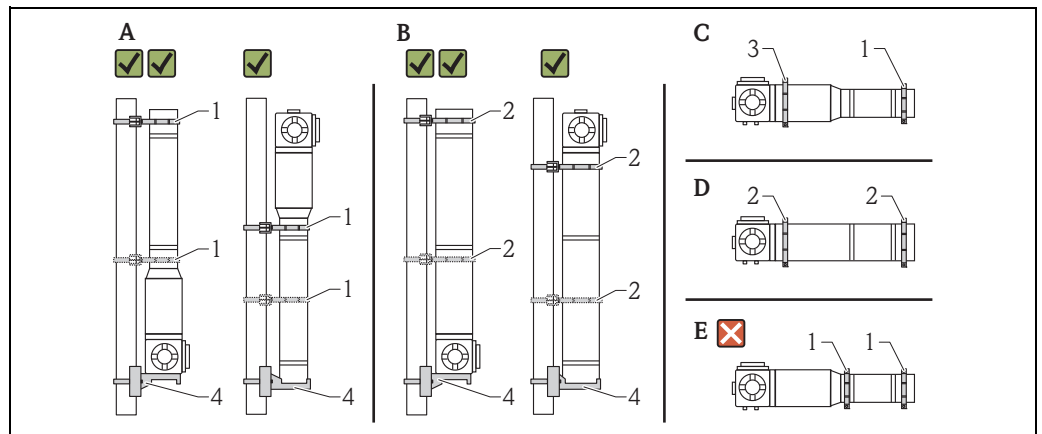

- | | |
|---|---|
| <p>A Level measurement, FMG60 without water jacket</p> <p>B Level measurement, FMG60 with water jacket</p> <p>C Level limit measurement, FMG60 without water jacket</p> <p>D Level limit measurement, FMG60 with water jacket</p> <p>E Such horizontal mounting not permitted</p> | <p>1 Retainer for pipe $\varnothing 80$ mm (3.15 in)</p> <p>2 Retainer for water cooling jacket, $\varnothing 140$ mm (5.51 in)</p> <p>3 Retainer for pipe $\varnothing 102$ mm (4.72 in)</p> <p>4 Bracket</p> |
|---|---|

CAUTION

Consider while mounting the device

- ▶ The mounting device must be fitted in a way such that it can withstand the weight of the Gammapilot M under all operating conditions to be expected.
- ▶ For a measuring length of 1600 mm (63 in) or more, two retainers (vertical) or three retainers (horizontal) must be used.
- ▶ For vertical mounting usage of the bracket or a support unit fitted by the customer is mandatory. Otherwise a sufficient stability and support of the Gammapilot M is not ensured.
- ▶ For stability reasons the mounting version with the compartment housing pointing upwards should only be used in exceptional cases (e.g. lack of space).
- ▶ To prevent damage of the detector tube, the maximum torque of the retainer screws is 6 Nm (4.42 lbf ft).

Ordering information

Detailed ordering information is available as follows:

- In the Product Configurator on the Endress+Hauser website: www.endress.com → Select country → Instruments → Select device → Accessories for FMG60
- From your Endress+Hauser sales center: www.endress.com/worldwide



Product Configurator - the tool for individual product configuration

- Configuration data updated on a daily basis
- Depending on the device: Direct input of data specific to measuring point, such as measuring range or operating language
- Automatic verification of exclusion criteria
- Automatic generation of order code with breakdown in PDF or Excel output format
- Possibility to order directly from the Endress+Hauser online shop

Clamping device for density measurement FHG61 For details, see SD01221F/00/EN.

Measurement section for density measurement FHG62 For drawings and description, see SD00540F/00/EN.

Supplementary documentation for Gammapilot M

Fields of Activities **FA00001F/00/EN**
 Product overview for applications in liquids and bulk solids

Technical Information **Fieldgate FXA320, FXA520**
 Technical Information for Fieldgate FXA320/520, TI00369F/00/EN.

Operating Instructions **Gammapilot M**
 Allocation of the Operating Instructions to the device:

Device type	Output	Operating Instructions	Description of Device Functions
FMG60	HART	BA00236F/00/EN	BA00287F/00/EN
	PROFIBUS PA	BA00329F/00/EN	
	FOUNDATION Fieldbus	BA00330F/00/EN	

Planning instructions PROFIBUS PA
 Guidelines for planning and commissioning, BA00034S/04/EN.

Safety Manual Functional Safety Manual for Gammapilot M, SD00230F/00/EN and SD00324F/00/EN.

Clamping device for density measurement FHG61 For details, see SD01221F/00/EN.

Measurement section for density measurement FHG62 For drawings and description, see SD00540F/00/EN.

Supplementary documentation for Radiation Sources, Source Containers and Modulator

Gamma Radiation Source FSG60, FSG61	TI00439F/00/EN <ul style="list-style-type: none"> ■ Technical Information for Gamma Radiation Sources FSG60/FSG61 ■ Returning source container ■ Type A packaging
Source container FQG60	TI00445F/00/EN Technical Information for Source Container FQG60
Source container FQG61, FQG62	TI00435F/00/EN Technical Information for Source Container FQG61 and FQG62
Source container FQG63	TI00446F/00/EN Technical Information for Source Container FQG63
Gammapilot FTG20	TI01023F/00/EN Technical Information for Gammapilot FTG20 BA00223F/00/EN Operating Instructions for Gammapilot FTG20
Source container QG2000	TI00346F/00/EN Technical Information for Source Container QG2000 BA00223F/00/EN Operating Instructions for Source Container QG2000
Gamma Modulator FHG65	TI00423F/00/EN Technical Information for Gamma Modulator FHG65 and Synchronizer FHG66 BA00373F/00/EN Operating Instructions for Gamma Modulator FHG65 and Synchronizer FHG66



71256385

www.addresses.endress.com
