

JUL-D50 单压力传感器

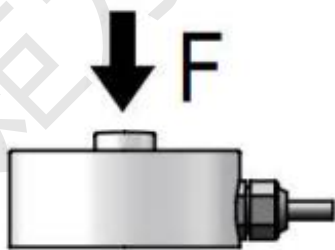

■传感器受力图 Force diagram of sensor



■传感器接线图 Sensor wiring diagram

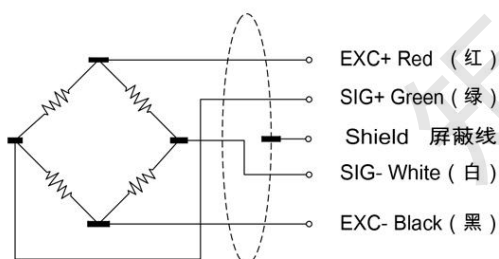

■特点与用途 Features&Applications

- ▶外形小巧，便于安装
- ▶压式承载设计，不锈钢材料，形变小
- ▶采用高精度电阻应变原理，动态响应频率高
- ▶主要用于汽车压装、自动化组装、3C 产品测试、机器人夹持力，医疗检测等工业测试、测量及自动控制 系统

技术参数 Technical specifications		
额定量程	Capacity	1-100KN (可选)
输出灵敏度	Rated output	1.0-2.0±0.05mV/V
零点输出	Zero balance	±0.03mV/V
非线性	Non-linearity	0.2%F.S
滞后	Hysteresis	0.1%F.S
重复性	Repeatability	0.1%F.S
输入电阻	Input impedance	780±20Ω
输出电阻	Output impedance	700±10Ω
绝缘电阻	Insulation	≥5000MΩ/100VDC
激励电压	Recommended excitation	5 ~ 15VDC
温度灵敏度漂移	Temp.effect.on output	0.05%F.S./10°C
零点温度漂移	Temp.effect.on zero	0.05%F.S./10°C
工作温度	Operation temp range	-20 ~ 80°C
安全超载	Safe overload	150%
极限超载	Ultimate overload	300%
防护等级	IP Class	IP65
电缆尺寸	Cable size	Φ4x3000mm
材质	Material	不锈钢

外形尺寸 External Dimension

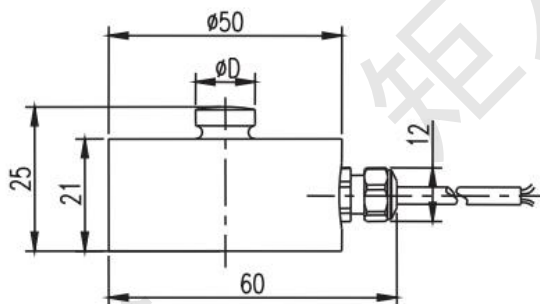
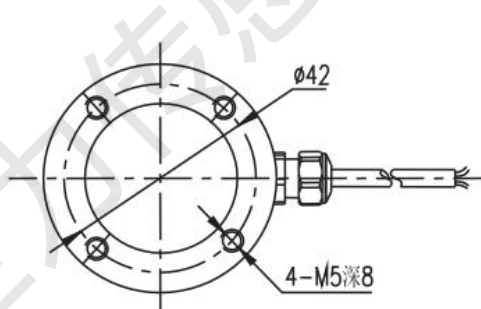

Capacity (kN)
1,2,5,10,20
50
100