

# Compact Rotary Level Control for Dry Solids & Powders



The economical and compact Mini-Rotary is designed for controlling material levels in smaller bins and hoppers that contain plastics, food, seed, chemicals and other dry powder and bulk solid materials. Its small size, yet rugged design allows for use of a level sensor where other types of equipment simply will not fit. Its principle of operation is simple ... a slow speed motor rotates the paddle when no material is present. Then, when material comes into contact with the paddle, the paddle stops and an alert – such as a light or horn – will notify the operator the bin is full. When the bin is emptied, the paddle again begins to rotate, alerting the operator that a refill is necessary.

## Ideal for Small Bins & Hoppers

The Mini-Rotary is designed for controlling the level of dry solids in small bins and hoppers that contain plastics, food, seed, chemicals, and other powder or bulk solid materials. It is easily integrated into process manufacturing, installing into constrained spaces where other types of equipment will not fit.

## Simple, Dependable Operation in Tight Spaces

The Mini-Rotary has few moving parts and is simple to install on the side or top of a bin. Its simple operation consists of a slow-speed synchronous motor rotating the paddle which senses the pressure of the material at the level where the Mini-Rotary is placed, detecting either high or low levels. It is appropriate for a variety of light to heavy materials – allowing for motor torque sensitivity to be easily adjusted.

Rotary technology ignores changing material characteristics that can cause other point level devices to fail; it simply senses the presence or absence of materials. A variety of paddles are available, making it suitable for a wide range of powder or bulk solids. A four-vane polycarbonate paddle is appropriate for light to medium density materials, while a bayonet style polycarbonate paddle is easily insertable through a ¾" pipe fitting and can be used with higher density materials.



# Mini-Rotary Level Control

# Compact Rotary Level Detector Fits Small Spaces



- Compact design ideal for small bins, hoppers, and feeders
- Simple to install to detect high or low levels
- No calibration required
- De-energizing motor extends motor life
- Motor slip-clutch prevents gear damage
- Adjustable motor torque sensitivity
- Mounts through 3/4" pipe fitting
- Optional four-vane or bayonet style sensing paddles

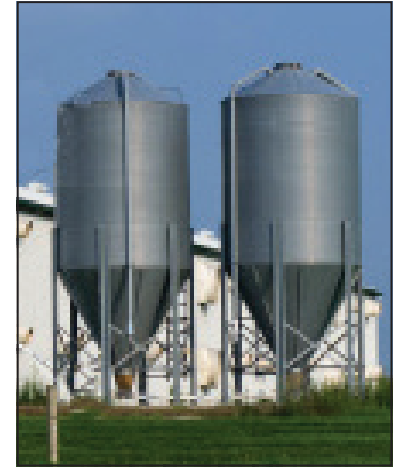

## Specifications

Input Voltage	110/230 VAC, 50/60 Hz
Power Consumption	1.5 Watts
Switch	SPDT (single pole, double throw)
Contact Rating	5A @ 250 VAC
Rotary Speed	1 RPM
Temperature Range	-40°F to +185°F (-40°C to +85°C)
Wiring Cable	18 AWG, 12 inch cable
Mounting	3/4" PF (pipe fitting)
Clutch	Magnetic slip clutch prevents damage to motor gears
Enclosure	Polycarbonate, NEMA 1
Weight	.77 lb.

## Dimensions

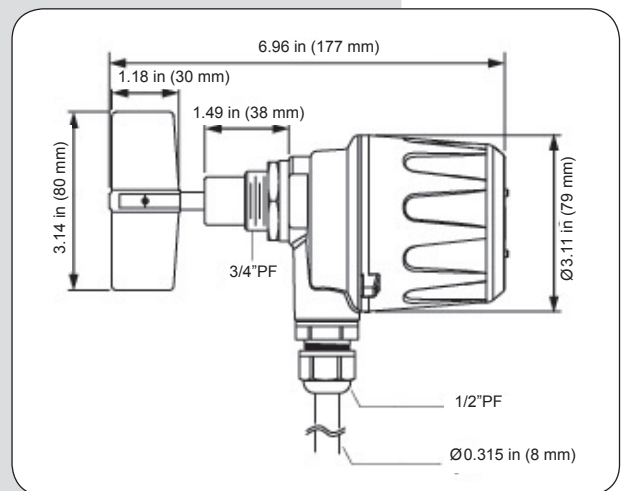

Shipping Address:  
7201 N. 98th St.  
Lincoln, NE 68507

Mailing Address:  
P.O. Box 29709  
Lincoln, NE 68529

800.278.4241 | 402.434.9102  
Fax: 402.434.9133  
www.binmaster.com