



Level



Pressure



Flow



Temperature

Liquid
Analysis

Registration

Systems
Components

Services



Solutions

Technical Information

Liquiphant S FTL70, FTL71

Vibronic

High-temperature point level switch for all kinds of liquids



The function is not affected by flow, turbulence, bubbles, foam, vibration, bulk solids content or buildup. The Liquiphant is thus the ideal substitute for float switches.

FTL70:

Compact design, also for pipes

FTL71:

With extension pipe up to 3 m (6 m on request)

High corrosion-resistant AlloyC4 (2.4610), AlloyC22 (2.4602) is available for the fork and process connections for applications in very aggressive liquids.

EEx ia, EEx de and EEx d protection enable it to be used in hazardous areas.

Your benefits

- Use in safety systems requiring functional safety to SIL2 in accordance with IEC 61508/IEC 61511-1
- With high-temperature resistant components: for process temperatures **to 280 °C** (300 °C for max. 50 h cumulative)
- With welded gas-tight feed-through: maximum safety in the event of damaged sensor
- Process connections from 3/4" and small tuning fork dimensions: also for areas difficult to access
- Large number of process connections to choose from: universal usage
- Wide variety of electronics, e.g. NAMUR, relay, DC-PMP, thyristor, PFM signal output: the right connection for every process control system
- PROFIBUS PA interface: for optimum startup and maintenance
- No adjustment: quick, low-cost startup
- No mechanically moving parts: no maintenance, no wear, long operating life
- Monitoring of fork for damage: guaranteed function

Application

The Liquiphant S is a point level switch which can be used in all liquids

- for process temperatures between -60 °C and 280 °C (300 °C for max. 50 h cumulative; without thermal shock restriction)
- for pressures up to 100 bar
- for viscosity up to 10,000 mm²/s
- for density of ≥ 0.5 g/cm³ or ≥ 0.7 g/cm³, other settings on request
- foam detection on request

Table of contents

Application	4	Connectable load	11
Point level detection	4		
Function and system design	4	Electronic insert FEL57 (PFM)	12
Measuring principle	4	Power supply	12
Modularity	4	Electrical connection	12
Electronic versions	5	Output signal	13
Galvanic isolation	5	Signal on alarm	13
Design	5	Connectable load	13
Input	5	Electronic insert FEL50A (PROFIBUS PA)	14
Measured variable	5	Power supply	14
Measuring range (detection range)	5	Electrical connection	14
Process density	5	Output signal	15
		Signal on alarm	15
Electronic insert FEL51 (AC)	6	Connection and function	16
Power supply	6	Connecting cables	16
Electrical connection	6	Safety mode	16
Output signal	6	Switching time	16
Signal on alarm	6	Switch-on behavior	16
Connectable load	6	Performance characteristics	16
Electronic insert FEL52 (DC PNP)	7	Reference operating conditions	16
Power supply	7	Maximum measured error	16
Electrical connection	7	Repeatability	16
Output signal	7	Hysteresis	16
Signal on alarm	7	Influence of process temperature	16
Connectable load	7	Influence of process density	16
		Influence of process pressure	16
Electronic insert FEL54 (AC/DC with relay output) ..	8	Operating conditions	17
Power supply	8	Installation	17
Electrical connection	8	Examples of mounting	17
Output signal	8	Orientation	19
Signal on alarm	8	Environment	19
Connectable load	8	Ambient temperature range	19
Electronic insert FEL55 (8/16 mA)	9	Ambient temperature limits	19
Power supply	9	Storage temperature	19
Electrical connection	9	Climate class	19
Output signal	9	Degree of protection	20
Signal on alarm	9	Vibration resistance	20
Connectable load	9	Electromagnetic compatibility	20
Electronic insert FEL56 (NAMUR L-H edge)	10	Process conditions	20
Power supply	10	Process temperature	20
Electrical connection	10	Thermal shock	20
Output signal	10	Process pressure pe	20
Signal on alarm	10	Test pressure	20
Connectable load	10	State of aggregation	20
		Density	21
Electronic insert FEL58 (NAMUR H-L edge)	11	Viscosity	21
Power supply	11	Solids content	21
Electrical connection	11	Lateral loading	21
Output signal	11	Medium conditions	21
Signal on alarm	11		

Mechanical construction	22
Design	22
Dimensions (in mm)	23
Weights	26
Material	26
Process connections	27
Human interface	28
Electronic inserts	28
Operating concept	28
Certificates and approvals	29
Certificates	29
CRN approval	29
Combinations of housings and electronic inserts	29
Ordering information	31
Ordering information Liquiphant S FTL70, FTL71	31
Accessories	35
Lap joint flange	35
Lap joint flanges	35
Sliding sleeves for unpressurized operation	35
High pressure sliding sleeves	36
Cover with sight glass	37
Cover with sight glass	37
Documentation	37
Operating Instructions	37
Technical Information	38
Functional safety (SIL)	38
Safety Instructions (ATEX)	39
Safety Instructions (NEPSI)	39
Control Drawings	39
System information	39

Application

Point level detection

Maximum or minimum detection in tanks or pipes containing all kinds of liquids from cold to very hot. The devices are also suitable for use in hazardous areas and for applications with high pressures.

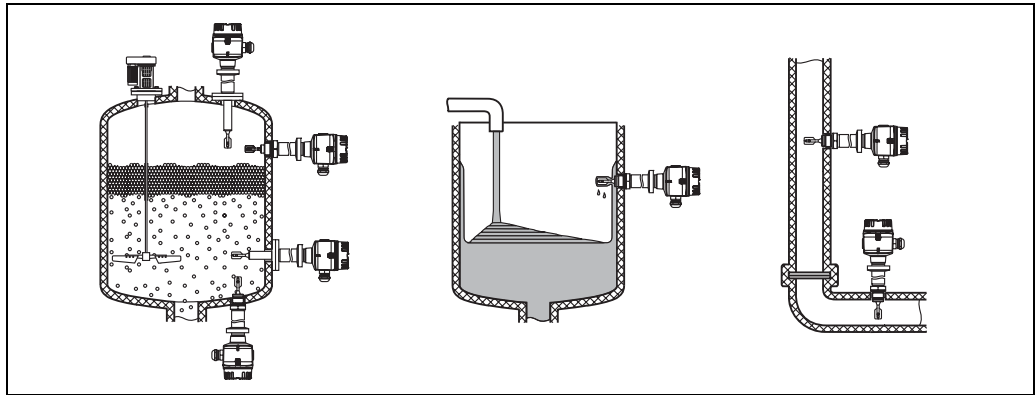

L00-FTL7xxxx-11-05-xx-xx-001

Function and system design

Measuring principle

The sensor's fork vibrates at its intrinsic frequency. This frequency is reduced when covered with liquid. This change in frequency causes the point level switch to switch.

Modularity

Point level switch

Liquiphant S FTL7x with electronic inserts FEL51, FEL52, FEL54

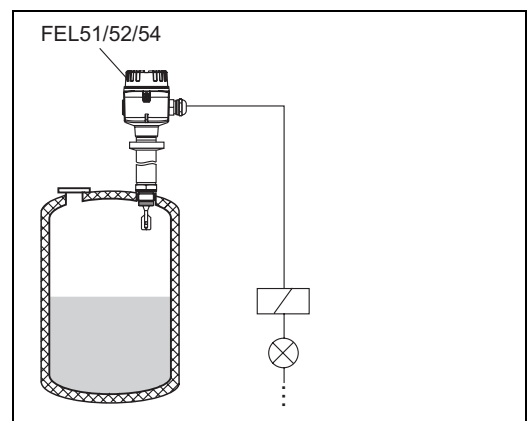

L00-FTL7xxxx-15-05-xx-xx-000

Point level switch

Liquiphant S FTL7x with electronic inserts FEL55, FEL56, FEL57, FEL58, FEL50A for connecting to a separate switching unit, an isolating amplifier or for connecting to a PROFIBUS PA segment coupler

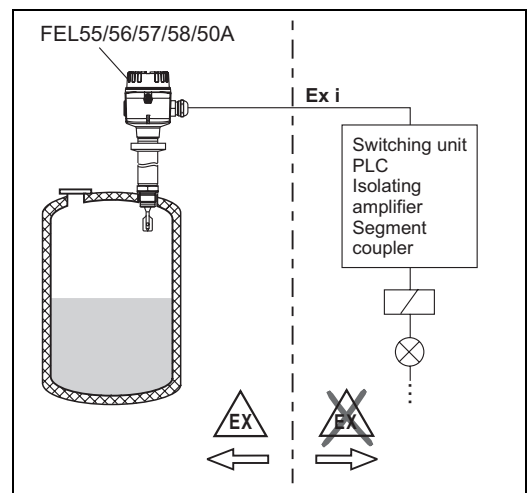

L00-FTL7xxxx-15-05-xx-en-000

Electronic versions	<p>FEL51: Two-wire AC version; Switches the load directly into the power supply circuit via the thyristor.</p> <p>FEL52: Three-wire DC version; Switches the load via the transistor (PNP) and separate connection.</p> <p>FEL54: Universal current version with relay output; Switches the loads via 2 floating change-over contacts.</p> <p>FEL55: For separate switching unit; signal transmission 16/8 mA on two-wire cabling.</p> <p>FEL56: For separate switching unit; signal transmission L-H edge 0.6 to 1.0 / 2.2 to 2.8 mA to EN 50227 (NAMUR) on two-wire cabling.</p> <p>FEL58: For separate switching unit; signal transmission H-L edge 2.2 to 3.5 / 0.6 to 1.0 mA to EN 50227 (NAMUR) on two-wire cabling. Checking of connecting cabling and other devices by pressing a key on the electronic insert.</p> <p>FEL57: For separate switching unit; PFM signal transmission; Current pulses superposed on the power supply along the two-wire cabling. Cyclical checking from the switching unit without changing levels.</p> <p>FEL50A: For connecting to PROFIBUS PA; Cyclic and acyclic data exchange acc. to PROFIBUS-PA Profile 3.0 Discrete Input</p>
----------------------------	--

Galvanic isolation	<p>FEL51, FEL52, FEL50A: Between sensor and power supply</p> <p>FEL54: Between sensor and power supply and load</p> <p>FEL55, FEL56, FEL57, FEL58: See connected switching unit</p>
---------------------------	---

Design	<p>FTL70: Compact</p> <p>FTL71: With extension pipe</p>
---------------	---

Input

Measured variable	Level (limit value)
Measuring range (detection range)	<p>FTL70: Depends on mounting point.</p> <p>FTL71: Depends on mounting point and the pipe extension. Standard 3000 mm (up to 6000 mm on request)</p>
Process density	Adjustment on the electronic insert > 0.5 g/cm ³ or > 0.7 g/cm ³ (other on request)

Electronic insert FEL51 (AC)

Power supply

Supply voltage: 19 to 253 V AC
 Power consumption: < 0.83 W
 Residual current consumption: < 3.8 mA
 Short-circuit protection
 Overvoltage protection FEL51: overvoltage category III

Electrical connection

Two-wire AC connection

Always connect in series with a load!

Check the following:

- The residual current in blocked state (up to 3.8 mA)
- That for low voltage
 - the voltage drop across the load is such that the minimum terminal voltage at the electronic insert (19 V) when blocked is not undershot.
 - the voltage drop across the electronics when switched through is observed (up to 12 V)
- That a relay cannot de-energize with holding power below 3.8 mA.
 If this is the case, a resistor should be connected parallel to the relay (RC module available on request => MVT291278).
- When selecting the relay, pay attention to the holding power/ rated power / rated power (see "Connectable load")

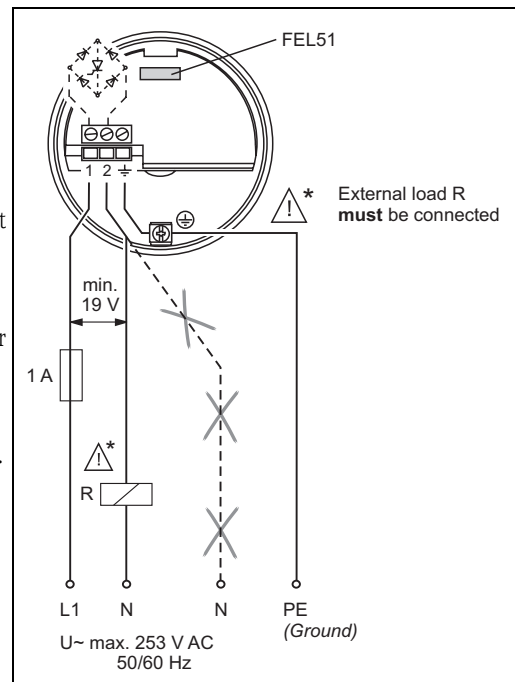

L00-FTL5xxxx-04-05-xx-xx-001

Output signal







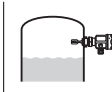

I_L = load current (switched through)

< 3.8 mA = residual current (blocked)

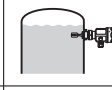
 = lit

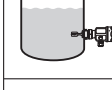
 = unlit

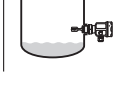
L00-FTL2xxxx-07-05-xx-xx-000

Safety mode	Level	Output signal	LEDs	
			green	red
Max.		1 I_L → 2		
		1 < 3.8 mA → 2		
Min.		1 I_L → 2		
		1 < 3.8 mA → 2		

L00-FTL5xxxx-04-05-xx-xx-001

Signal on alarm

Output signal on power failure or in the event of damaged sensor: < 3.8 mA

Connectable load

- For relays with a minimum holding power/rated power > 2.5 VA at 253 V (10 mA) or > 0.5 VA at 24 V (20 mA)
- Relays with a lower holding power/rated power can be operated by means of an RC module connected in parallel.
- For relays with a maximum holding power/rated power < 89 VA at 253 V or < 8.4 VA at 24 V
- Voltage drop across FEL51 max. 12V
- Residual current with blocked thyristor max. 3.8 mA.
- Load switched directly into the power supply circuit via the thyristor.
 Transient (40 ms) max. 1.5 A, max. 375 VA at 253 V or max. 36 VA at 24 V (not short-circuit proof)

Electronic insert FEL52 (DC PNP)

Power supply

DC voltage: 10 to 55 V
 Ripple: max. 1.7 V, 0 to 400 Hz
 Current consumption: max. 15 mA
 Power consumption: max. 0.83 W
 Reverse polarity protection
 Overvoltage protection FEL52: overvoltage category III

Electrical connection

Three-wire DC connection

Preferably used with programmable logic controllers (PLC).
 DI module as per EN 61131-2.
 Positive signal at switching output of the electronics (PNP);
 Output blocked on point level.

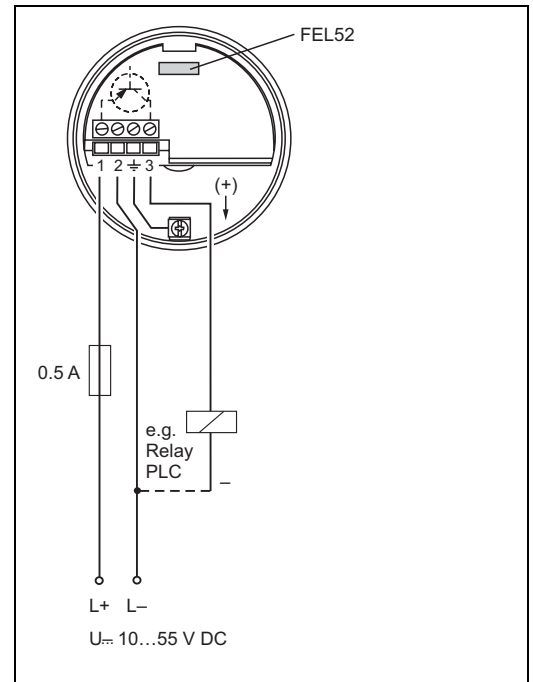

L00-FTL5xxxx-04-05-xx-en-001

Output signal

I_L = load current (switched through)

$< 100 \mu A$ = residual current (blocked)

= lit

= unlit

L00-FTL2xxxx-07-05-xx-xx-000

Safety mode	Level	Output signal	LEDs	
			green	red
Max.		$L+ \xrightarrow{I_L} +$ 1 → 3		
		$1 \xrightarrow{< 100 \mu A} 3$		
Min.		$L+ \xrightarrow{I_L} +$ 1 → 3		
		$1 \xrightarrow{< 100 \mu A} 3$		

L00-FTL5xxxx-04-05-xx-xx-004

Signal on alarm

Output signal on power failure or in the event of damaged sensor: $< \mu 100 A$

Connectable load

- Load switched via the transistor and separate PNP connection, max. 55 V
- Load current max. 350 mA (pulsed overload and short-circuit protection)
- Residual current $< 100 \mu A$ (with transistor blocked).
- Capacitance load max. $0.5 \mu F$ at 55 V, max. $1.0 \mu F$ at 24 V
- Residual voltage $< 3 V$ (with transistor switched through);

Electronic insert FEL54 (AC/DC with relay output)

Power supply

AC voltage: 19 to 253 V, 50/60 Hz or DC voltage: 19 to 55 V
 Power consumption: max. 1.3 W
 Reverse polarity protection
 Overvoltage protection FEL54: overvoltage category III

Electrical connection

Universal current connection with relay output

Power supply:
 Please note the different voltage ranges for AC and DC.
 AC.

Output:
 When connecting an instrument with high inductance, provide a spark arrester to protect the relay contact.
 A fine-wire fuse (depending on the load connected) protects the relay contact on short-circuiting.
 Both relay contacts switch simultaneously.

* When jumpered, the relay output works with NPN logic.

** See "Connectable load" below

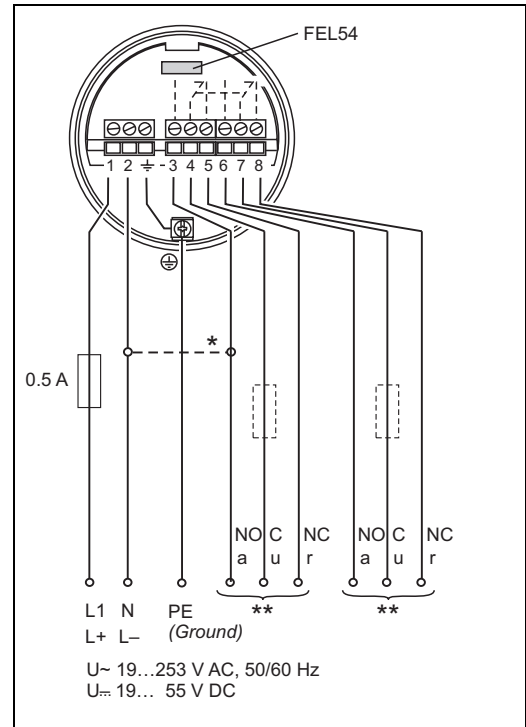

L00-FTL5xxxx-04-05-xx-xx-002

Output signal

- = relay energized
- = relay de-energized
- = lit
- = unlit

L00-FTL2xxxx-07-05-xx-xx-001

Safety mode	Level	Output signal	LEDs	
			green	red
Max.				
Min.				

L00-FTL5xxxx-04-05-xx-xx-003

Signal on alarm

Output signal on power failure or in the event of damaged sensor: relay de-energized

Connectable load

- Loads switched via 2 floating change-over contacts (DPDT).
- I~ max. 6 A (Ex de 4 A), U~ max. 253 V AC; P~ max. 1500 VA, cos φ = 1, P~ max. 750 VA, cos φ > 0.7
- I= max. 6 A (Ex de 4 A) to 30 V DC, I= max. 0.2 A to 125 V
- When connecting a low-voltage circuit with double isolation according to IEC 1010, the following applies: total of voltages of relay output and power supply max. 300 V.

Electronic insert FEL55 (8/16 mA)

Power supply

Supply voltage: 11 to 36 V DC
 Power consumption: < 600 mW
 Reverse polarity protection
 Overvoltage protection FEL55: overvoltage category III

Electrical connection

Two-wire connection for separate switching unit

For connecting to programmable logic controllers (PLCs) for example, AI module 4 to 20 mA to EN 61131-2. Output signal jump from high to low current on point level.

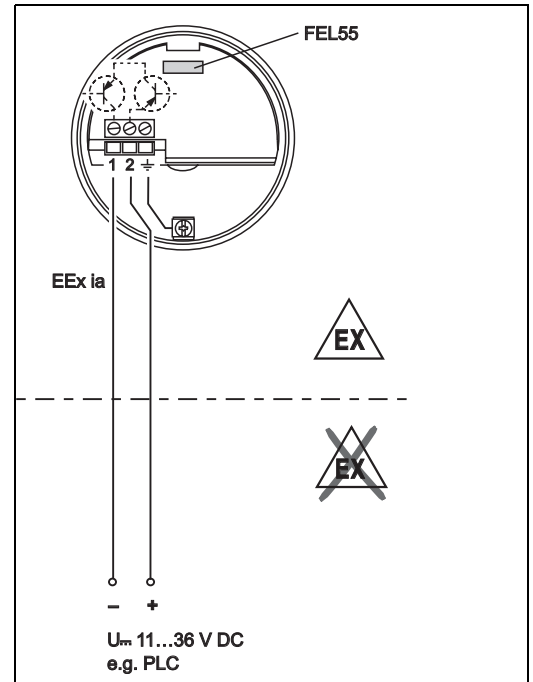

L00-FTL5xxxx-04-05-xx-en-000

Output signal

$\sim 16 \text{ mA} = 16 \text{ mA} \pm 5 \%$

$\sim 8 \text{ mA} = 8 \text{ mA} \pm 6 \%$

= lit

= unlit

L00-FTL2xxxx-07-05-xx-xx-000

Safety mode	Level	Output signal	LEDs	
			green	red
Max.		+ 2 $\xrightarrow{\sim 16 \text{ mA}}$ 1		
		+ 2 $\xrightarrow{\sim 8 \text{ mA}}$ 1		
Min.		+ 2 $\xrightarrow{\sim 16 \text{ mA}}$ 1		
		+ 2 $\xrightarrow{\sim 8 \text{ mA}}$ 1		

L00-FTL5xxxx-04-05-xx-xx-000

Signal on alarm

Output signal on power failure or in the event of damaged sensor: < 3.6 mA

Connectable load

- $R = (U - 11 \text{ V}) : 16.8 \text{ mA}$
- $U = \text{connection voltage: } 11 \text{ to } 36 \text{ V DC}$

Example:
 PLC with 250 Ω with 2-wire version

$250 \Omega = (U - 11 \text{ V}) / 16.8 \text{ mA}$

$4.2 [\Omega/\text{A}] = U - 11 \text{ V}$

$U = 15.2 \text{ V}$

Electronic insert FEL56 (NAMUR L-H edge)

Power supply

Power consumption: < 6 mW at I < 1 mA; < 38 mW at I = 2.2 to 4 mA
 Connection data interface: IEC 60947-5-6

Electrical connection

Two-wire connection for separate switching unit

For connecting to isolating amplifiers acc. to NAMUR (IEC 60947-5-6), e.g. FTL325N, FTL375N from Endress+Hauser.
 Output signal jump from low to high current on point level.

(L-H edge)

Connecting to multiplexer:
 Set clock time to min. 2 s.

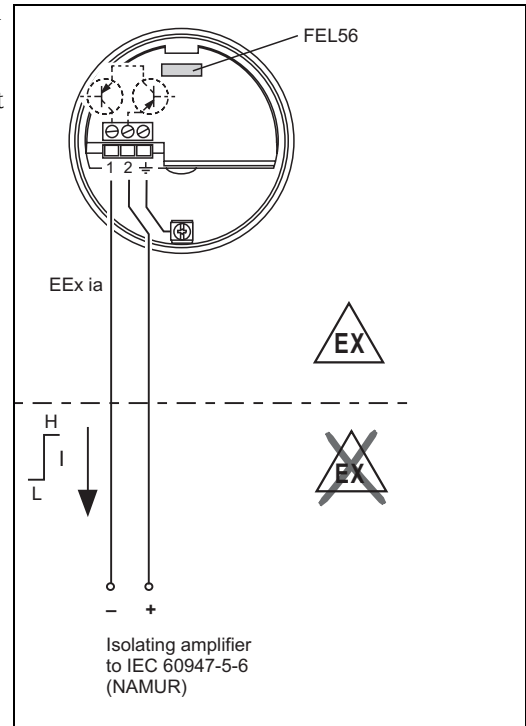

L00-FTL5xxxx-04-05-xx-xx-004

Output signal

- = lit
- = flashes
- = unlit

L00-FTL5xxxx-07-05-xx-xx-002

Safety mode	Level	Output signal	LEDs	
			green	red
Max.		+ 0.6 ... 1.0 mA 2 → 1		
		+ 2.2 ... 2.8 mA 2 → 1		
Min.		+ 0.6 ... 1.0 mA 2 → 1		
		+ 2.2 ... 2.8 mA 2 → 1		

L00-FTL5xxxx-04-05-xx-xx-003

Signal on alarm

Output signal in the event of damaged sensor: > 2.2 mA

Connectable load

See Technical Data of the isolating amplifier connected according to IEC 60947-5-6 (NAMUR)

Electronic insert FEL58 (NAMUR H-L edge)

Power supply

Power consumption: < 6 mW at I < 1 mA; < 38 mW at I = 2.2 to 4 mA
 Connection data interface: IEC 60947-5-6

Electrical connection

Two-wire connection for separate switching unit

For connecting to isolating amplifiers acc. to NAMUR (IEC 60947-5-6), e.g. FTL325N, FTL375N from Endress+Hauser.

Output signal jump from high to low current on point level.

(H-L edge)

Additional function:
 Test key on the electronic insert.
 Pressing the key breaks the connection to the isolating amplifier.



Note!

In Ex-d applications, the additional function can only be used if the housing is not exposed to an explosive atmosphere.

Connecting to multiplexer:
 Set clock time to min. 2 s.

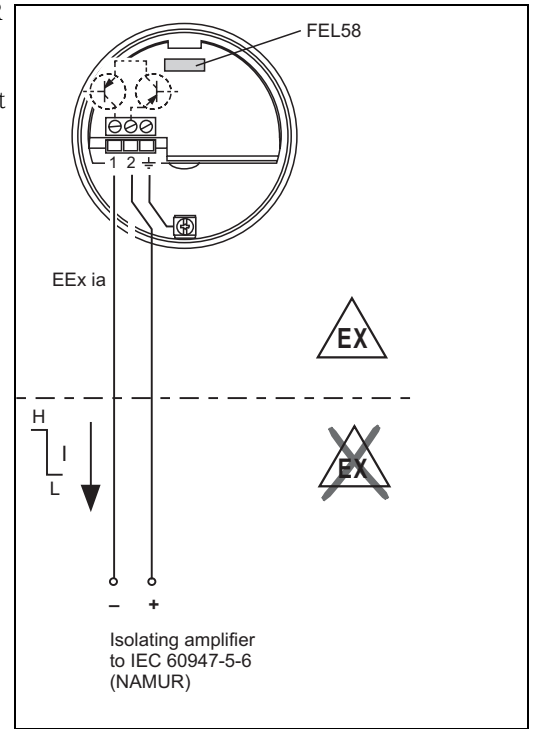

L00-FTL5xxxx-04-05-xx-en-002

Output signal

Safety mode	Level	Output signal	LEDs	
			green	yellow
Max.		+ 2.2 ... 3.5 mA 2 → 1		
		+ 0.6 ... 1.0 mA 2 → 1		
Min.		+ 2.2 ... 3.5 mA 2 → 1		
		+ 0.6 ... 1.0 mA 2 → 1		

- = lit
- = flashes
- = unlit

L00-FTL5xxxx-07-05-xx-xx-002

L00-FTL5xxxx-04-05-xx-xx-007

Signal on alarm

Output signal in the event of damaged sensor: < 1.0 mA

Connectable load

- See Technical Data of the isolating amplifier connected according to IEC 60947-5-6 (NAMUR)
- Connection also to isolating amplifiers which have special safety circuits (I > 3.0 mA)

Electronic insert FEL57 (PFM)

Power supply

Supply voltage: 9.5 to 12.5 V DC
 Current consumption: 10 to 13 mA
 Power consumption: < 150 mW
 Reverse polarity protection

Electrical connection

Two-wire connection for separate switching unit

For connecting to Nivotester switching units:
 FTL320, FTL325P, FTL370, FTL372, FTL375P
 (also with cyclical checking), from
 Endress+Hauser.

Output signal jump of the PFM signal from high to low
 frequency when sensor is covered.

Switching between minimum/maximum safety
 in the Nivotester.

Additional function "cyclical checking":

After interruption of the power supply,
 a test cycle is activated
 which checks the sensor and electronics
 without any change in level.

Approved for overfill protection acc. to WHG (German
 Water Resources Act).

The following can be switched at the electronic insert:

– Standard

(STD):

Corrosion of the fork unlikely;
 simulation approx. 8 s
 tuning fork exposed – covered – exposed.
 This setting tests level reporting in the Nivotester
 during cyclical checking.

– Extended (EXT):

Corrosion of the fork possible;
 Simulation approx. 41 s: tuning fork exposed –
 covered – corroded – exposed.
 This setting tests level reporting and alarm
 notification in the Nivotester during cyclical
 checking.

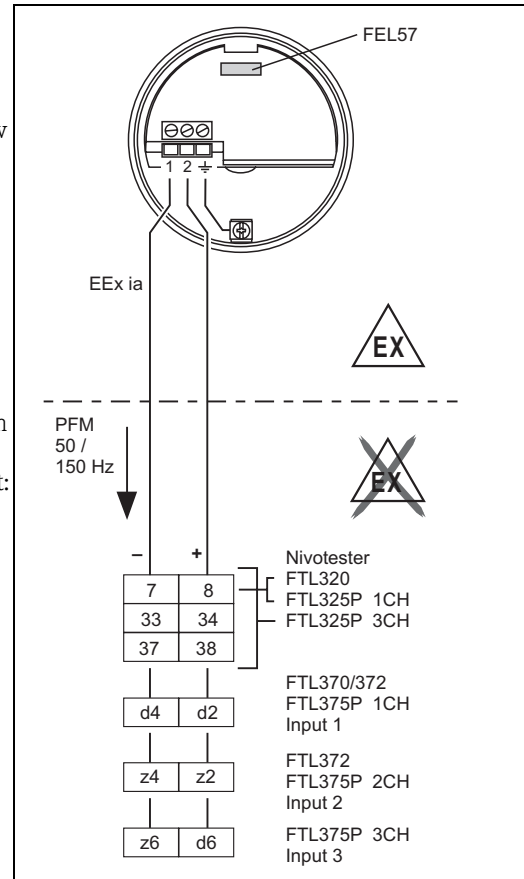

L00-FTL5xxxx-04-05-xx-en-003

Switching behavior of the connected device:

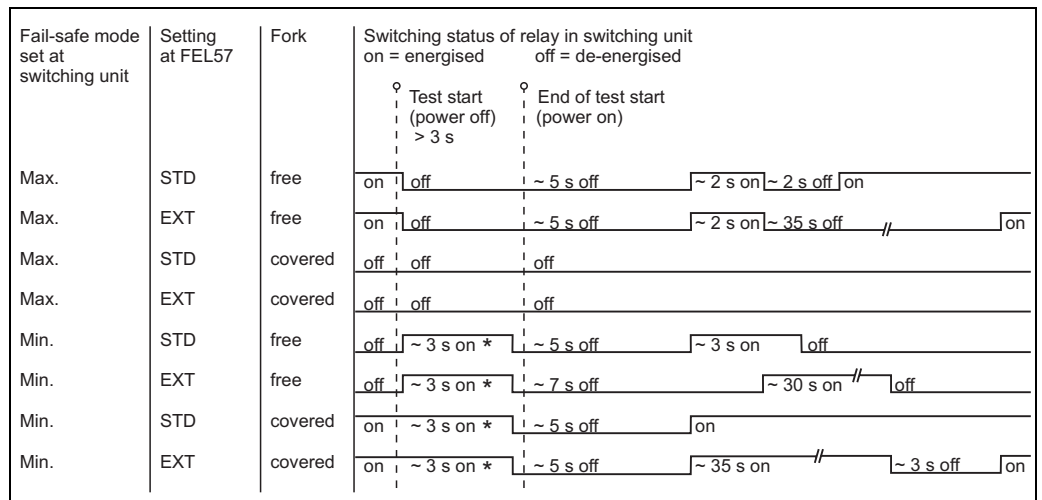

L00-FTL5xxxx-05-05-xx-en-000

* De-energized on power supply failure

Please note this switching response and function of the plant especially when replacing a Liquiphant with an EL17Z or FEL37 electronic insert using a Liquiphant S with FEL57 electronic insert.

Output signal

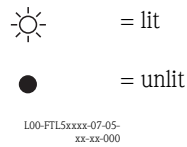

Safety mode	Level	Output signal (PFM)	LEDs	
			green	yellow
		150 Hz		
		50 Hz		

L00-FTL5xxxx-04-05-xx-xx-000

Signal on alarm

Output signal on power failure or in the event of damaged sensor: 0 Hz

Connectable load

- Floating relay contacts in the connected switching device Nivotester FTL320, FTL325P, FTL370, FTL372, FTL375P
- For contact load, see the Technical Data of the switching unit.

Electronic insert FEL50A (PROFIBUS PA)

Power supply

Bus voltage: 9 to 32 V DC

Bus current:

- 12.5 mA +/- 1.0 mA (software version: 01.03.00, hardware version: 02.00)
- 10.5 mA +/- 1.0 mA (software version: 01.03.00, hardware version: 01.00)

Electrical connection

Two-wire connection for power supply and data transfer

For connecting to PROFIBUS PA

Additional functions:

- Digital communication enables the representation, reading and editing of the following parameters:
Fork frequency, switch-on frequency, switch-off frequency, switch-on time and switch-off time, status, measured value, density switch.
- Matrix locking possible
- Switch to WHG mode possible (WHG approval).
- For a detailed description, see BA198F
- You can also visit www.profibus.com for more information

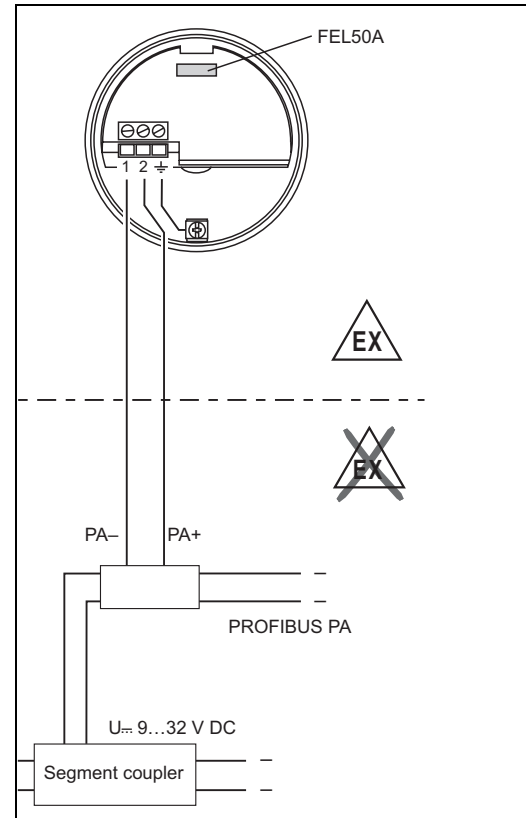

L00-FTL5xxxx-04-05-zx-en-005

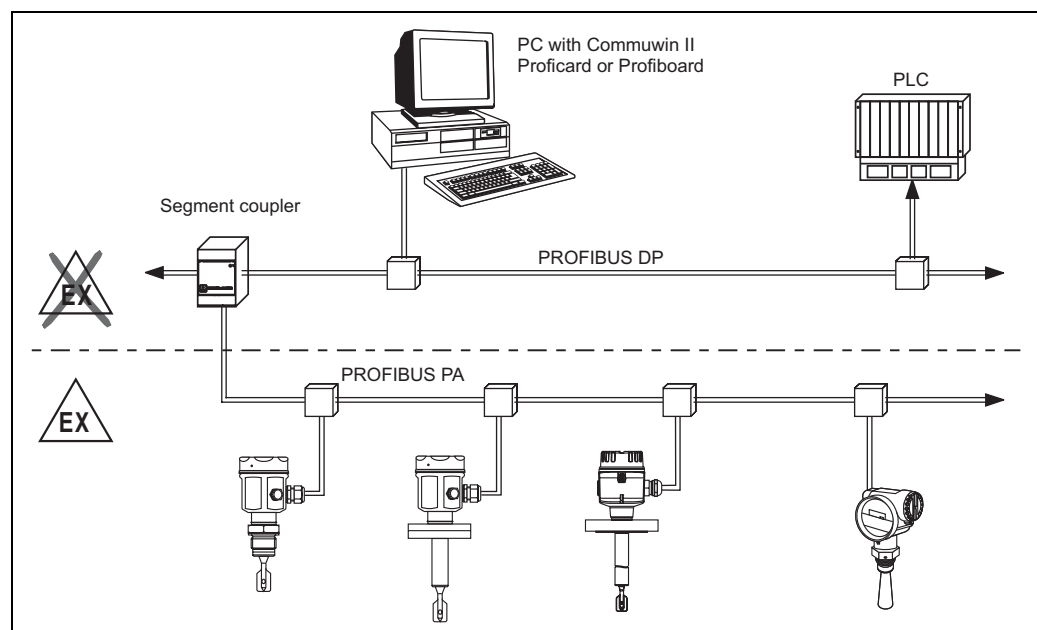

L00-FTL5xxxx-04-05-zx-en-006

Output signal

☀ = lit
● = unlit

L00-FTL2xxxx-07-05-
xx-xx-000

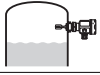
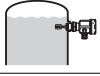
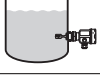
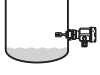
Setting	Level	LEDs		FEL50A
		green	yellow	
not inverted		☀	●	OUT_D = 0 PA bus signal
		☀	☀	OUT_D = 1 PA bus signal
inverted		☀	☀	OUT_D = 1 PA bus signal
		☀	●	OUT_D = 0 PA bus signal

L00-FTL5xxxx-04-05-xx-xx-000

Signal on alarm

- Failure information can be opened using the following interfaces:
Yellow LED flashing, status code, diagnostic code; see BA198F

Connection and function

Connecting cables	<ul style="list-style-type: none"> ■ Electronic inserts: cross-section max. 2.5 mm²; strand in ferrule to DIN 46228 ■ Protective earth in housing: cross-section max. 2.5 mm² ■ External equipotential bonding connection on housing: cross-section max. 4 mm²
--------------------------	--

Safety mode	<p>Minimum/maximum residual current safety selectable on electronic insert. (with FEL57 on Nivotester only)</p> <p>Max. = maximum safety: The output switches to the power fail response when the fork is covered For use with overflow protection for example</p> <p>Min. = minimum safety: The output switches to the power fail response when the fork is exposed For use with dry running protection for example</p>
--------------------	--

Switching time	<p>When fork is covered: approx. 0.5 s When fork is exposed: approx. 1.0 s (Other switching times on request.)</p> <p>Additionally configurable for PROFIBUS PA: 0.5-60 s</p>
-----------------------	---

Switch-on behavior	<p>When switching on the power supply, the output assumes the alarm signal. After max. 3 s it assumes the correct switching mode (exception: FEL57)</p>
---------------------------	---

Performance characteristics

Reference operating conditions	<p>Ambient temperature: 23 °C Process temperature: 23 °C Process density: 1 g/cm³ (water) Viscosity: 1 mm²/s Process pressure p_e: 0 bar Sensor mounting: vertical from above Density switch: to > 0.7</p>
---------------------------------------	--

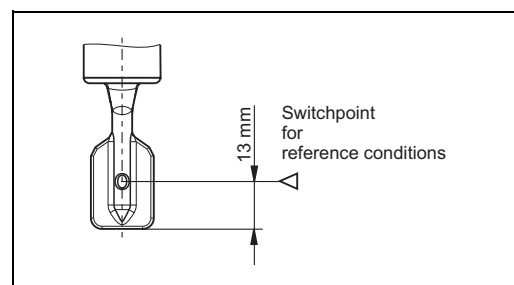

L00-FTL5xxxx-06-05-xx-xx-000

Maximum measured error	Specified by mounting position: max. +/- 1mm
-------------------------------	--

Repeatability	0.1 mm
----------------------	--------

Hysteresis	Approx. 2 mm
-------------------	--------------

Influence of process temperature	Max. +1.4 to -5.5 mm (-60 to +280 °C)
---	---------------------------------------

Influence of process density	Max. +4.8 to -3.5 mm (0.5 to 1.5 g/cm ³)
-------------------------------------	--

Influence of process pressure	Max. 0 to -3.9 mm (-1 to 100 bar)
--------------------------------------	-----------------------------------

Operating conditions

Installation

Installation instructions

Switch points \triangleright on the sensor depend on the mounting position, with reference to water, Density 1 g/cm³, 23 °C, p_e 0 bar.

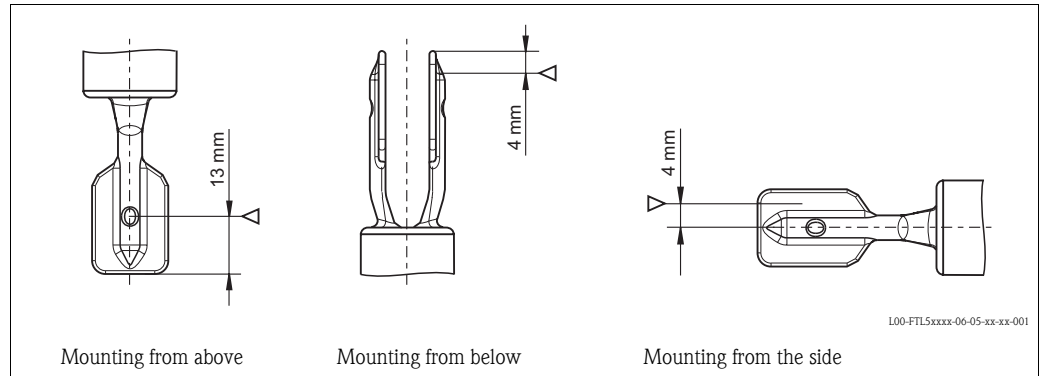

Examples of mounting

Examples of mounting with regard to the viscosity ν of the liquid and the tendency to form buildup

Optimum mounting, without problem even with high viscosity:

Position the fork so that the narrow edge of the tines is vertical. This ensures that the liquid can run off easily.

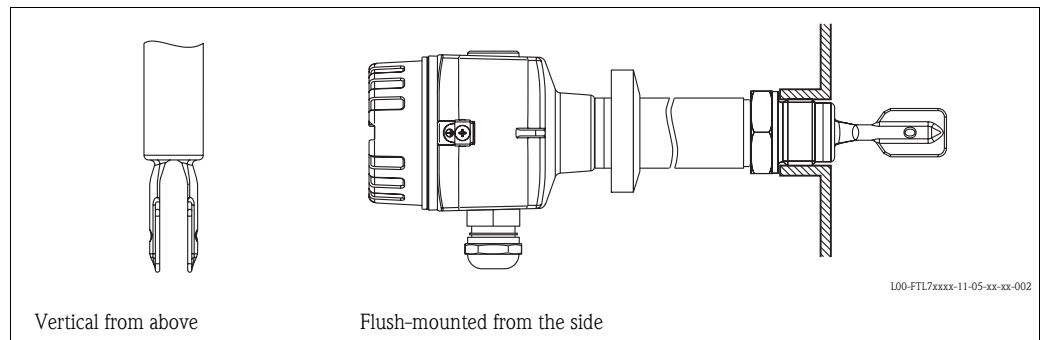

With buildup on the tank walls:

* Ensure that there is sufficient distance between the buildup expected on the tank wall and the fork.

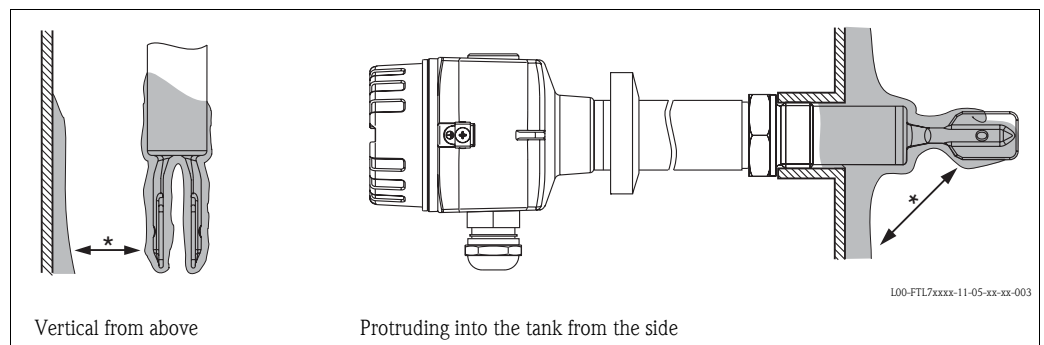

Mounting positions with low viscosity (up to 2000 mm²/s):

* Deburr the nozzle surfaces

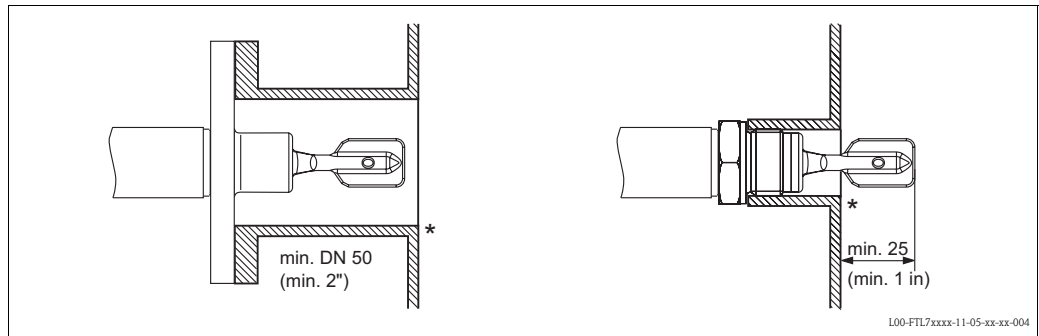

Mounting in piping from 2":

Fluid velocities up to 5 m/s for viscosity 1 mm²/s and density 1 g/cm³.
(Check the function for other process conditions.)

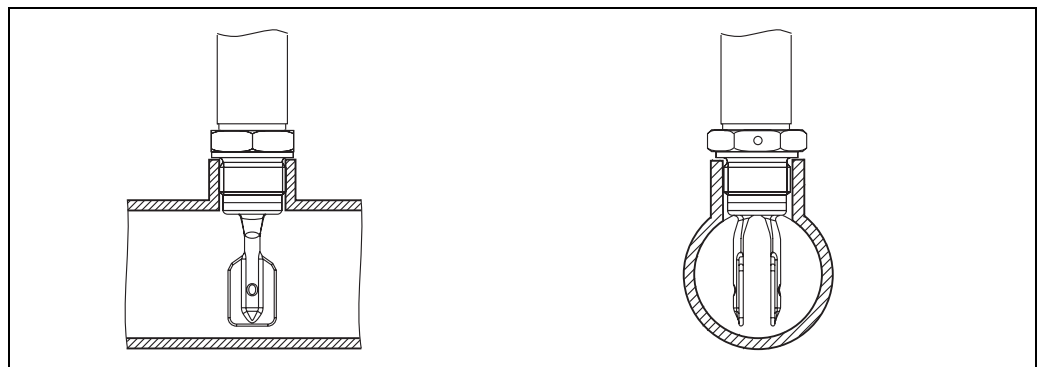

Support the Liquiphant S FTL71
in the event of severe dynamic load.

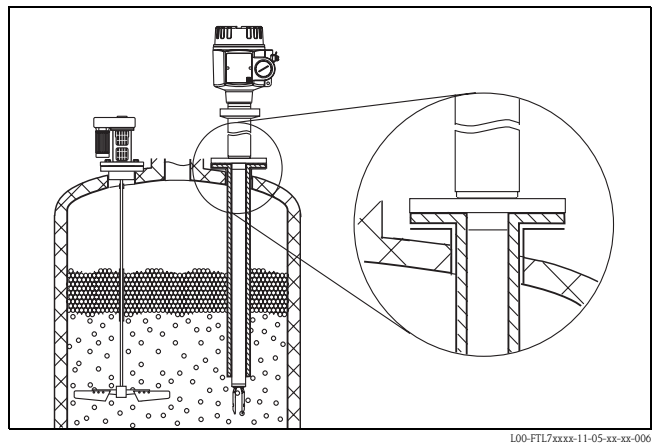

Ensure adequate space outside the tank for mounting, connection and configuration.

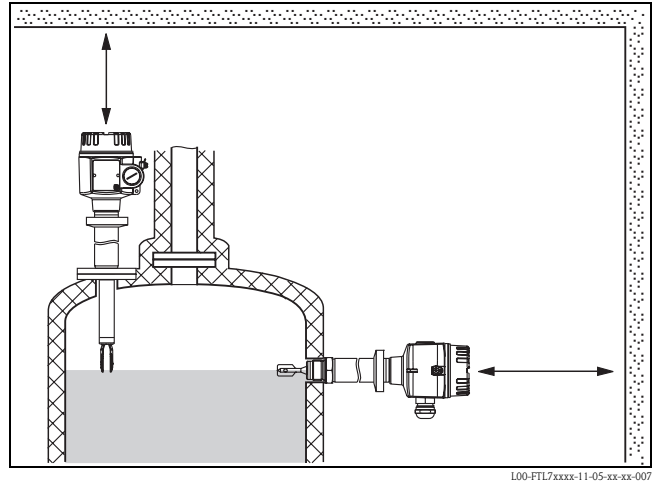

L00-FTL7xxxx-11-05-xx-xx-007

Orientation FTL70, and FTL71 with short pipe (up to approx. 500 mm) - any position, FTL71 with long pipe - vertical

Environment

Ambient temperature range Permitted ambient temperature T_a at the housing depending on the process temperature T_p in the tank:

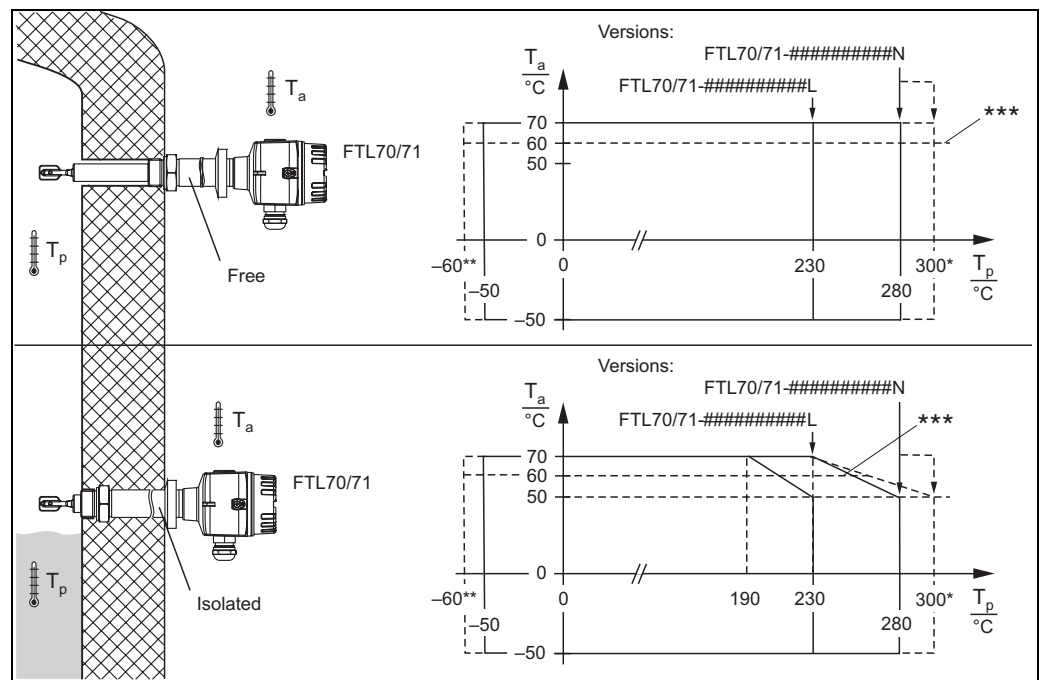

L00-FTL7xxxx-05-05-xx-en-000

* Maximum of 50 hours cumulative
 ** -60 °C only for ATEX and CSA certificates
 *** FEL50A maximum +60 °C ambient temperature (T_a) in hazardous area

Ambient temperature limits -50 to +70 °C

Storage temperature -50 to +80 °C

Climate class Climate protection to IEC 68, Part 2-38, Fig. 2a

Degree of protection

Types of housing	IP65	IP66*	IP67*	IP68*	IP69k	NEMA4X**
Polyester housing F16	–	X	X	–	–	X
Stainless steel housing F15	–	X	X	–	–	X
Aluminum housing F17	X	X	X	–	–	X
Aluminum housing F13	X	X	–	X***	–	X
Stainless steel housing F27	–	X	–	X	–	4X/6P
Aluminum housing T13 with separate connection compartment (Ex d)	X	X	–	X***	–	4X/6P

* As per EN60529

** As per NEMA 250

*** Only with M20 cable entry or G1/2 thread

Vibration resistance

To IEC 68, Part 2-6 (10 to 55 Hz, 0.15 mm, 100 cycles)

Electromagnetic compatibility

Interference emission to EN 61326, Electrical Equipment Class B

Interference immunity to EN 61326; Annex A (Industrial) and NAMUR Recommendation NE 21 (EMC)

Process conditions

Process temperature

–60 to +280 °C (300 °C for max. 50 h cumulative)

Thermal shock

Without restriction within the process temperature range.

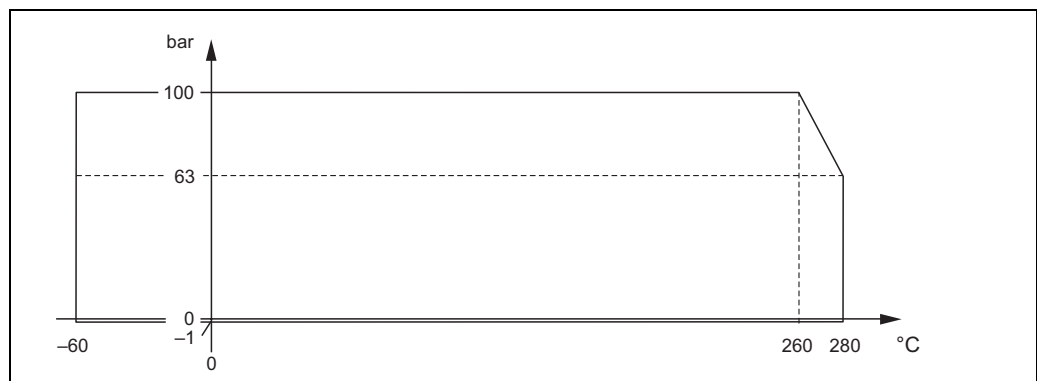
Process pressure p_e 

Please refer to the standards listed for the permitted pressure values of the flanges at higher temperatures:

- pR EN 1092–1: 2005

With regard to their stability-temperature property, the materials 1.4435 and 1.4404 (SS 316L) are identical and are grouped together under 13E0 in EN1092-1, Tab. 18. The chemical composition of the two materials can be identical.

- ASME B 16.5a - 1998 Tab. 2-2.2 F316
- ASME B 16.5a - 1998 Tab. 2.3.8 N10276
- JIS B 2220

The lowest value from the derating curves of the device and selected flange applies in each case.

Test pressure

Max. 150 bar at 20 °C (no function during test pressure)

Burst pressure of diaphragm 400 bar

State of aggregation

Liquid

Density	$\geq 0.7 \text{ g/cm}^3 =$ delivery status $\geq 0.5 \text{ g/cm}^3$ * can be adjusted via switches * Density settings for the compact housing on request
Viscosity	Max. 10000 mm ² /s
Solids content	Max. \varnothing 5 mm
Lateral loading	$\leq 75 \text{ Nm}$
Medium conditions	The service life of the device can be affected in applications involving a high level of hydrogen diffusion through the metal process isolating diaphragm of the sensor. Typical conditions: temperature $>180 \text{ }^\circ\text{C}$ and pressure $> 64 \text{ bar}$

Mechanical construction

Design

Summary of all electrical and mechanical versions

Plug-in electronic inserts to mount in the housing

 <p>L00-FTL5xxxx-03-05-xx-xx-000</p>	FEL51:	Two-wire AC connection
	FEL52:	Three-wire DC connection PNP
	FEL54:	Universal current connection, 2 relay outputs
	FEL55:	Output 16/8 mA for separate switching unit
	FEL56:	Output 0.6 to 1.0 / 2.2 to 2.8 mA for separate switching unit (NAMUR)
	FEL58:	Output 2.2 to 3.5 / 0.6 to 1.0 mA for separate switching unit (NAMUR)
	FEL57:	Output 150/50 Hz, PFM, for separate switching unit (Nivotester)
FEL50A:	Digital communication PROFIBUS PA	

Housing

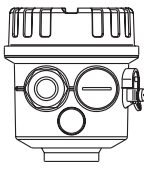
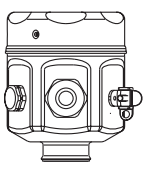
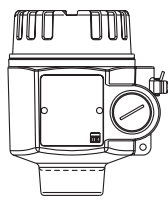
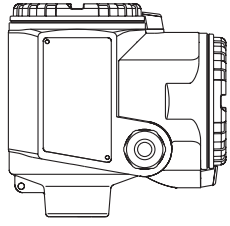
 <p>L00-FTL5xxxx-03-05-xx-xx-001</p>	 <p>L00-FTL5xxxx-03-05-xx-xx-002</p>	 <p>L00-FTL5xxxx-03-05-xx-xx-003</p>	 <p>L00-FTL5xxxx-03-05-xx-xx-004</p>
F16 Polyester (PBT)	F15 Stainless steel (316L)	F13 Coated aluminum (also for Ex d) F17 Coated aluminum F27 Stainless steel (316L), (also for Ex d)	T13 Aluminum with separate connection compartment (also Ex de and Ex d), coated

Temperature spacer

Temperature spacer with welded gas-tight feed-through
(standard version)

Approx. 160 mm to 230 °C ("L")

Approx. 200 mm to 280 °C ("N")

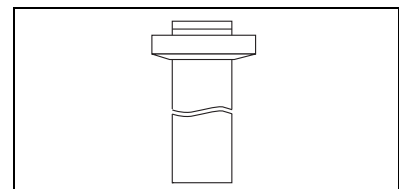

Process connections

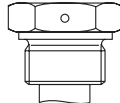
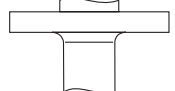
 <p>L00-FTL5xxxx-03-05-xx-xx-006</p>	 <p>L00-FTL5xxxx-03-05-xx-xx-007</p>	 <p>L00-FTL5xxxx-03-05-xx-xx-009</p>
G 3/4, DIN ISO 228/1 R 3/4, DIN 2999 NPT 3/4, ANSI B 1.20.1 (AF 32)	G 1, DIN ISO 228/1 R 1, DIN 2999 NPT 1, ANSI B 1.20.1 (AF 41)	Flanges to DIN, ANSI, JIS from DN 25 / 1"

Sensors

Compact or with extension pipe up to 3 m
(6 m on request)

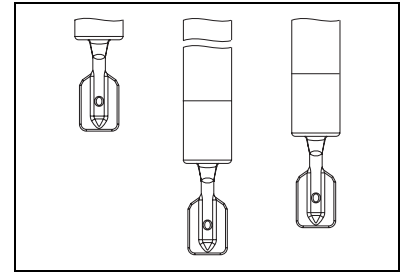

L00-FTL5xxxx-03-05-xx-xx-018

Dimensions (in mm)

Housing and sensor FTL70/71

Polyester housing F16

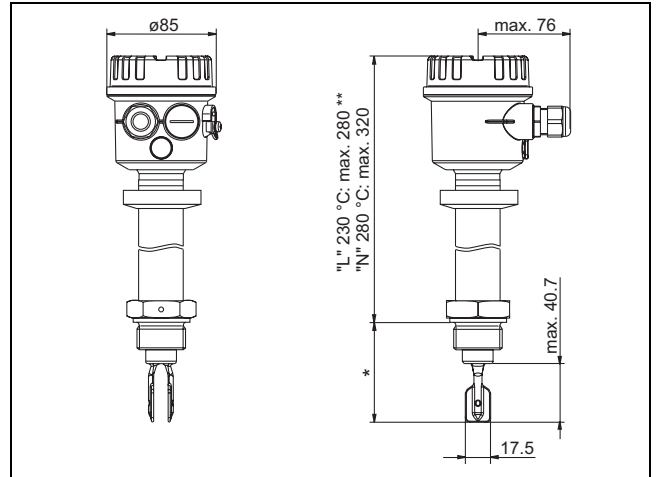

L00-FTL7xxxx-06-05-xx-xx-001

Stainless steel housing F15

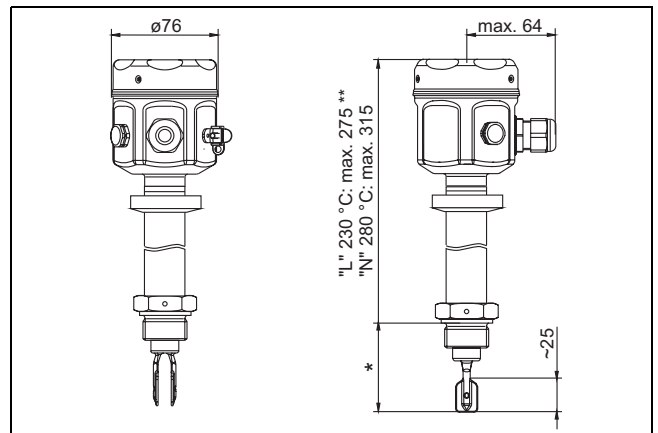

L00-FTL5xxxx-06-05-xx-xx-005

* see Process connections

** "L" = Version FTL70/71 - # # # # # # # # L for 230 °C

"N" = Version FTL70/71 - # # # # # # # # N for 280 °C

Aluminum housing F17/F13
 Stainless steel housing (316L) F27
 (F13 also for Ex d)

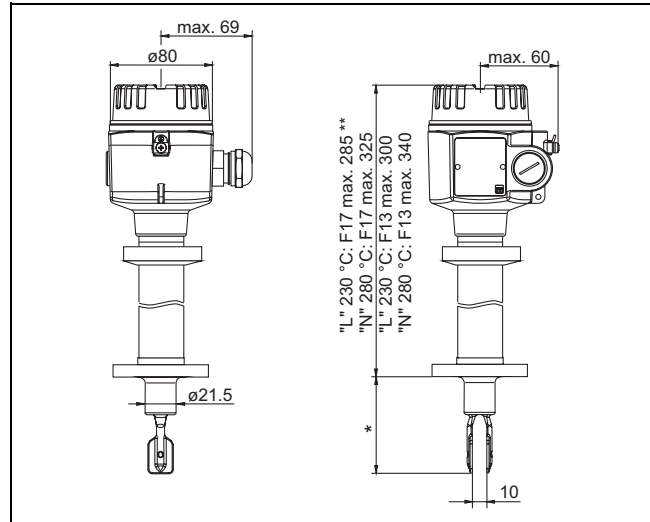

L00-FTL7xxxx-06-05-xx-xx-00

Aluminum housing T13
 with separate connection compartment

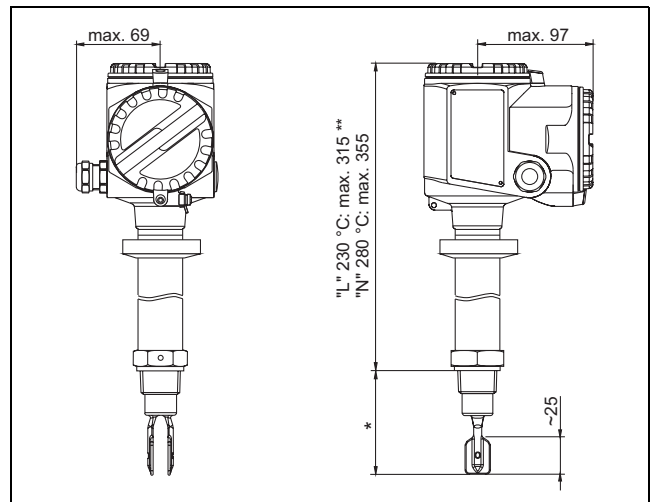

L00-FTL7xxxx-06-05-xx-xx-00

* see Process connections
 ** "L" = Version FTL70/71 - ##### L for 230 °C
 "N" = Version FTL70/71 - ##### N for 280 °C

The dimensions apply to process connections with G, R, NPT threads;
 for flanged versions, dimensions may be up to 30 mm bigger.

Temperature spacer

Provides sealed insulation
 for the vessel and normal ambient
 temperatures for the housing.

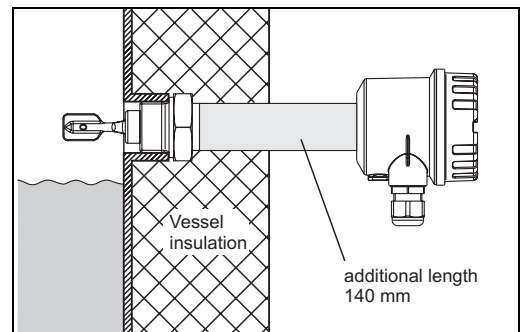

L00-FTL5xxxx-11-05-xx-en-000

Process connections

Process connection		Dimensions	Accessories	Pressure Temperature
G 3/4 DIN ISO 228/1 with elastomer flat seal to DIN 7603 (supplied)	GQ2 GQ5 GQ6	<p>L00-FTL5xxxx-06-05-xx-en-001</p>	Flat seal to DIN 7603; installed on site	Max. 100 bar Max. 280 °C
G 1 DIN ISO 228/1 with elastomer flat seal to DIN 7603 (supplied)	GR2 GR5 GR6	<p>L00-FTL5xxxx-06-05-xx-en-002</p>	Flat seal to DIN 7603; installed on site	Max. 100 bar Max. 280 °C
NPT 3/4 ANSI B 1.20.1 or R 3/4 DIN 2999	GM2 GM5 GM6 GE2 GE5 GE6	<p>L00-FTL5xxxx-06-05-xx-en-004</p>		Max. 100 bar Max. 280 °C
NPT 1 ANSI B 1.20.1 or R 1 DIN 2999	GN2 GN5 GN6 GF2 GF5 GF6	<p>L00-FTL5xxxx-06-05-xx-en-005</p>		Max. 100 bar Max. 280 °C
Flanges ANSI B 16.5 EN 1092-1 (DIN 2527 B) JIS B2220	A## B## C## K##	<p>L00-FTL5xxxx-06-05-xx-xx-008</p>	Seal depending on design; installed on site	See nominal pressure of flange, however Max. 100 bar Max. 280 °C At high temperatures: note pressure capacity of flange depending on the temperature!
Alloy C4/C22-plated flanges are available for higher chemical-resistance. The flange carrier material comprises 316L and is welded with a 2 to 3 mm thick Alloy C4/C22 disk.				

Sensor length L for FTL71

The sensor length L depends on the process connection.

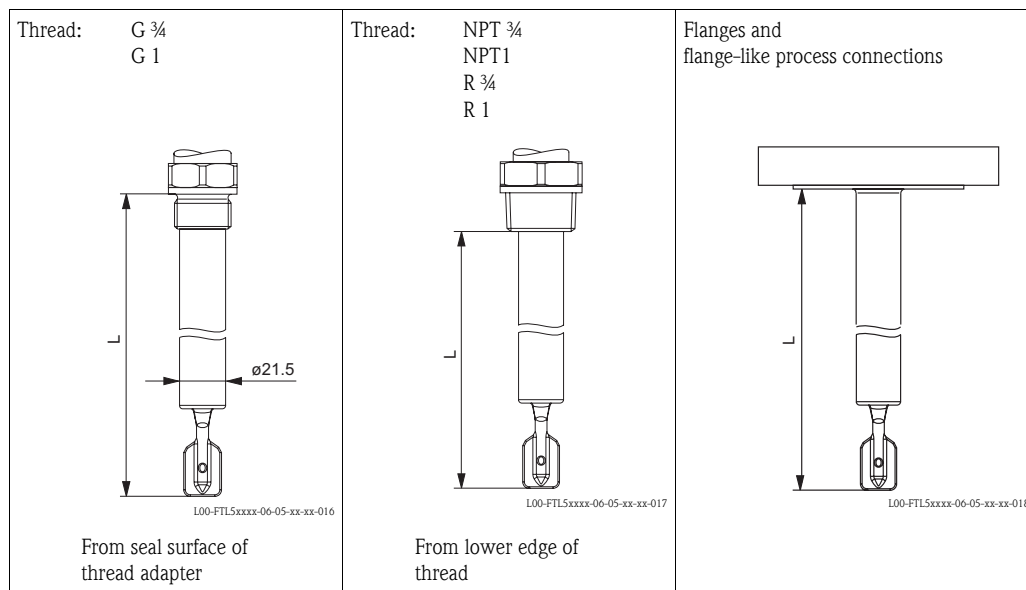

Any length L:

148 mm to 3000 mm (6 to 115 in); special version (TSP) on request up to 6000 mm (235 in)

Weights

See ordering information: → 31

Material

Material specifications as per AISI and DIN-EN.

Parts in contact with process

- Process connection and extension pipe: 316L (1.4435), optionally 2.4610 (AlloyC4), 2.4602 (AlloyC22)
- Tuning fork: S31803 (1.4462), optionally 2.4610 (AlloyC4), 2.4602 (AlloyC22)
- Flanges: 316L (1.4435 or 1.4404)
- Flange plating: AlloyC4, AlloyC22
- Flat seal for process connection G $\frac{3}{4}$ or G 1: elastomer fiber, asbestos-free

Parts with no process contact

- Tuning fork/housing seal: EPDM
- Temperature spacer: 316 L (1.4435)
- Pressure-tight feed-through: 316L (1.4435)
- Grounding at housing (outside): 304 (1.4301)
- Nameplate at housing (outside): 304 (1.4301)
- Cable glands
 - Housing F13, F15, F16, F17: polyamide (PA)
 - With B or C approval (→ 31 ordering information): nickel-plated brass
 - Housing F27: 316L (1.4435)
 - Housing T13: nickel-plated brass
- Polyester housing F16: PBT-FR with PBT-FR cover or with PA12 transparent cover,
 - Cover seal: EPDM
 - Nameplate glued: polyester film (PET)
 - Pressure compensation filter: PBT-GF20
- Stainless steel housing F15: 316L (1.4404)
 - Cover seal: silicone
 - Safety claw: 304 (1.4301)
 - Pressure compensation filter: PBT-GF20, PA
- Aluminum housing F17/F13: EN-AC-AISi10Mg, plastic-coated,
 - Cover seal: EPDM
 - Safety claw: nickel-plated brass
 - Pressure compensation filter: silicone
- Stainless steel housing F27: 316L (1.4435)
 - Cover seal: FVMQ (optional: EPDM seal available as spare part)

- Safety claw: 316L (1.4435)
- Aluminum housing T13: EN-AC-ALSi10Mg, plastic-coated,
 - Cover seal: EPDM
 - Safety claw: nickel-plated brass

Process connections

- Parallel thread G $\frac{3}{4}$, G 1 to DIN ISO 228/I, flat seal to DIN 7603, installed on site
- Tapered thread R $\frac{3}{4}$, R 1 to DIN 2999 Part 1
- Tapered thread $\frac{3}{4}$ -14 NPT, 1 - 1 1/2 NPT to ANSI B 1.20.1
- Flanges as per (for standards see Ordering information →  31+):
 - EN/DIN from DN 25
 - ANSI B16.5 from 1"
 - JIS B2220 (RF)

Human interface

Electronic inserts

With FEL51, FEL52, FEL54, FEL55:

- 2 switches for safety mode and density change,
- green LED to indicate operational status,
- red LED to indicate the switching status, flashes in the event of corrosion damage on sensor or if the electronics are defective

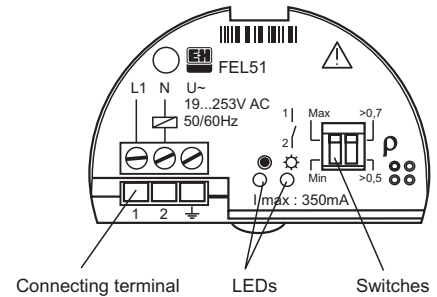

L00-FTL5xxxx-03-05-xx-en-001

With FEL56:

- 2 switches for safety mode and density change,
- green LED to indicate operational status,
- red LED to indicate the switching status, flashes in the event of corrosion damage on sensor or if the electronics are defective



L00-FTL5xxxx-03-05-xx-en-013

With FEL57:

- 2 switches for density change and cyclical checking,
- green LED to indicate operational status,
- yellow LED to indicate the covered status, flashes in the event of corrosion damage on sensor or if the electronics are defective

With FEL58:

- 2 switches for safety mode and density change,
- green LED
 - flashes quickly to indicate operational status,
 - flashes slowly in the event of corrosion damage on sensor or if the electronics are defective
- yellow LED to indicate the switching status, Test key – breaks the cable connection

With FEL50A:

- 8 switches for configuring the device address
- green LED to indicate operational status, pulsing to indicate communication;
- yellow LED to indicate switching status, flashes in the event of corrosion damage on sensor or if the electronics are defective

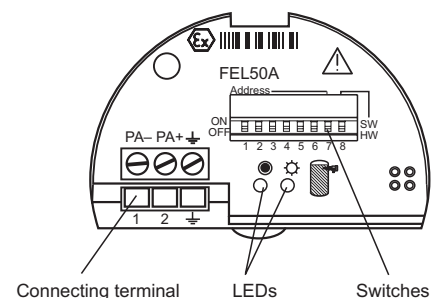





L00-FTL5xxxx-03-05-xx-en-002

Operating concept

Onsite configuration

Certificates and approvals

Certificates

- See Liquiphant S FTL70 FTL71 ordering information →  31
 - Leak-detection system in conjunction with WHG approval
Approval number: Z-65.40-446
(See also "Ordering information" →  31)
 - TSE Certificate of Suitability
The following applies to wetted device components:
 - They do not contain any materials derived from animals.
 - No additives or operating materials derived from animals are used in production or processing.
-  **Note!**
Wetted device components are listed in the "Mechanical construction" (→  22+) and "Ordering information" (→  31) sections.

CRN approval

Versions with a CRN approval: 0F10904.5C (Canadian Registration Number) are marked with a "*" in ordering information (→  31+) feature 20 "process connection".

Combinations of housings and electronic inserts

Please refer to the Safety Instructions on ATEX, NEPSI etc. for the permitted combinations of housing versions and electronic inserts. A list of the available documents can be found on →  39+. The actual documents can be found on the product pages at www.endress.com.

Abbreviations used:

Housing		Electronic inserts	
F16 polyester housing		FEL50A Profibus PA	
F17 aluminum housing (plug-in)		FEL51 SIL 2-wire 19-253VDC	
F13 aluminum housing (threaded)		FEL52 3-wire PNP	
T13 aluminum housing (separate connection compartment)		FEL54 relay DPDT 19-253VAC/19-55VDC	
F15 stainless steel housing (for hygiene applications)		FEL55 8/16mA, 11-36VDC	
F27 stainless steel housing (precision casting)		FEL56 NAMUR (L-H signal)	
		FEL57 2-wire PFM	
		FEL58 NAMUR+ test keys (H-L signal)	
A:	Non-hazardous area	F16, F17, F13, T13, F15, F27	FEL51/52/54 FEL50A/55/56/57/58
B:	ATEX/NEPSI II 3G EEx nC II T6, WHG	F16, F17, F13, T13, F15, F27	FEL54
C:	ATEX/NEPSI II 3G EEx nA II T6, WHG	F16, F17, F13, T13, F15, F27	FEL51/52 FEL50A/55/56/57/58
D:	Non-hazardous area, WHG	F16, F17, F13, T13, F15, F27	FEL51/52/54 FEL50A/55/56/57/58
E:	ATEX II 1/2G EEx de IIC T6, WHG/IEC Zone 0/1	T13	FEL51/52/54 FEL50A/55/56/57/58
F:	ATEX II 1/2GD Ex ia IIC T6, WHG/IEC	F17, F13, T13, F15, F27	FEL50A/55/56/57/58
L:	ATEX II 1/2G EEx d IIC T6, WHG/IECE Zone 0/1	F13, T13, F27	FEL51/52/54 FEL50A/55/56/57/58
M:	NEPSI Ex ia IIC T6	F16, F17, F13, T13, F15, F27	FEL50A/55/56/57/58
N:	NEPSI Ex d IIC T6	F13, T13, F27	FEL51/52/54 FEL50A/55/56/57/58
P:	FM IS Cl.I, II, III Div.1 Gr.A-G, Zone 0, 1, 2, 20, 21, 22	F16, F17, F13, T13, F15, F27 (with NPT cable entry)	FEL50A/55/56/57/58
Q:	FM XP Cl.I, II, III Div.1 Gr.A-G, Zone 1, 2, 21, 22	F13, T13, F27	FEL51/52/54 FEL50A/55/56/57/58
R:	FM NI Cl.I Div.2 Gr.A-D, Zone 2	F16, F17, F13, T13, F15, F27	FEL51/52/54 FEL50A/55/56/57/58
S:	CSA IS Cl I, II, III Div.1 Gr.A-G, Zone 0, 1, 2	F16, F17, F13, T13, F15, F27 (with NPT cable entry)	FEL50A/55/56/57/58
T:	CSA XP Cl I, II, III Div.1 Gr.A-G, Zone 1, 2	F13, T13, F27	FEL51/52/54 FEL50A/55/56/57/58
U:	CSA General Purpose	F16, F17, F13, T13, F15, F27	FEL51/52/54 FEL50A/55/56/57/58

V:	TIIS Ex ia IIC T2	F16, F17, F13, T13, F15, F27	FEL50A/55/56/57/58
W:	TIIS Ex d IIC T2	F13, T13, F27	FEL51/52/54 FEL50A/55/56/57/58
Y:	Other certificate (for non-hazardous area)		



Note! Polyester housing F16 (PBT)

Electrical connecting cables run in pipes:

Do not screw cable entries firmly to the piping. Use flexible connections (e.g. with armored hose).

If piping is used for grounding, then ensure that there is a continuous electrical connection.

Ordering information



Note!

Versions that are mutually exclusive are not indicated in this list.

Ordering information Liquiphant S FTL70 FTL71

Design		Basic weight			
FTL70	Compact		0.7 kg		
FTL71	With extension pipe		0.7 kg		
10	Approval:				
A	Non-hazardous area				
B	ATEX/NEPSI II 3 G	EEx nC II T6	Overfill protection to WHG (Germany)		
C	ATEX/NEPSI II 3 G	EEx nA II T6	Overfill protection to WHG (Germany)		
D	Non-hazardous area		Overfill protection to WHG (Germany)		
E	ATEX II 1/2 G	EEx de IIC T6	Overfill protection to WHG, IEC Ex Zone 0/1		
F	ATEX II 1/2 G	EEx ia IIC T6	Overfill protection to WHG, IEC Ex Zone 0/1		
	ATEX II 1/2 D	T 80°C*			
L	ATEX II 1/2 G	EEx d IIC T6	Overfill protection to WHG, IEC Ex Zone 0/1		
M	NEPSI	Ex ia IIC T6			
N	NEPSI	Ex d IIC T6			
P	FM	IS, Class I, II, III	Division 1, Group A-G		
Q	FM	XP, Class I, II, III	Division 1, Group B-G, for E5 housing Group A-G		
R	FM	NI, Class I	Division 2, Group A-D		
S	CSA	IS, Class I, II, III	Division 1, Group A-G		
T	CSA	XP, Class I, II, III	Division 1, Group A-G		
U	CSA	General Purpose			
V	TIIS	Ex ia IIC T2			
W	TIIS	Ex d IIC T2			
Y	Special version				
	*) Not for PBT				
20	Process connection:				
	Threaded connection				
GO2	G ¾	316L	Thread ISO 228		
GO5	G ¾	Alloy C4	Thread ISO 228		
GO6**	G ¾	AlloyC22	Thread ISO 228		
GR2	G 1	316L	Thread ISO 228		
GR5	G 1	Alloy C4	Thread ISO 228		
GR6**	G 1	AlloyC22	Thread ISO 228		
GE2	R ¾	316L	Thread DIN 2999		
GE5	R ¾	Alloy C4	Thread DIN 2999		
GE6**	R ¾	AlloyC22	Thread DIN 2999		
GF2	R 1	316L	Thread DIN 2999		
GF5	R 1	Alloy C4	Thread DIN 2999		
GF6**	R 1	AlloyC22	Thread DIN 2999		
GM2*	NPT ¾	316L	Thread ANSI		
GM5*	NPT ¾	Alloy C4	Thread ANSI		
GM6**	NPT ¾	AlloyC22	Thread ANSI		
GN2*	NPT1	316L	Thread ANSI		
GN5*	NPT1	Alloy C4	Thread ANSI		
GN6**	NPT1	AlloyC22	Thread ANSI		
	EN flanges				
B82	DN25	PN25/40 A	316L	Flange EN 1092-1 (DIN 2527 B)	1.4 kg
C82	DN25	PN25/40 B1	316L	Flange EN 1092-1 (DIN 2527 C)	1.3 kg
C85	DN25	PN25/40	Alloy C4 >1.4462	Flange EN 1092-1 (DIN 2527)	1.3 kg
C86**	DN25	PN25/40 B1	AlloyC22 >1.4462	Flange EN 1092-1 (DIN 2527)	1.3 kg
D82	DN25	PN40 B1	316L	Flange EN 1092-1 (DIN 2526 D)	1.4 kg
BB2	DN32	PN25/40 A	316L	Flange EN 1092-1 (DIN 2527 B)	2.0 kg
BD2	DN40	PN25/40 A	316L	Flange EN 1092-1 (DIN 2527 B)	2.4 kg

20	Process connection:					Additional weight	
	CF2	DN50	PN10/16 B1	316L	Flange EN 1092-1 (DIN 2527 C)	2.5 kg	
	BG2	DN50	PN25/40 A	316L	Flange EN 1092-1 (DIN 2527 B)	3.2 kg	
	CG2	DN50	PN25/40 B1	316L	Flange EN 1092-1 (DIN 2527 C)	2.9 kg	
	DG2	DN50	PN40 B1	316L	Flange EN 1092-1 (DIN 2526 D)	2.9 kg	
	CG5	DN50	PN25/40	Alloy C4 >1.4462	Flange EN 1092-1 (DIN 2527)	2.9 kg	
	CG6**	DN50	PN25/40 B1	AlloyC22 >1.4462	Flange EN 1092-1 (DIN 2527)	2.9 kg	
	BI2	DN50	PN63 A	316L	Flange EN 1092-1 (DIN 2527 B)	4.5 kg	
	CI2	DN50	PN63 B2	316L	Flange EN 1092-1 (DIN 2527 E)	4.5 kg	
	CI5	DN50	PN63	Alloy C4 >1.4462	Flange EN 1092-1 (DIN 2527)	4.5 kg	
	CI6**	DN50	PN63 B1	AlloyC22 >1.4462	Flange EN 1092-1 (DIN 2527)	4.5 kg	
	BJ2	DN50	PN100 A	316L	Flange EN 1092-1	5.5 kg	
	CJ2	DN50	PN100 B2	316L	Flange EN 1092-1	5.5 kg	
	BK2	DN65	PN25/40 A	316L	Flange EN 1092-1 (DIN 2527 B)	4.3 kg	
	CM2	DN80	PN10/16 B1	316L	Flange EN 1092-1 (DIN 2527 C)	4.8 kg	
	BN2	DN80	PN25/40 A	316L	Flange EN 1092-1 (DIN 2527 B)	5.9 kg	
	CN2	DN80	PN25/40 B1	316L	Flange EN 1092-1 (DIN 2527 C)	5.2 kg	
	DN2	DN80	PN40 B1	316L	Flange EN 1092-1 (DIN 2526 D)	5.2 kg	
	CN5	DN80	PN25/40	Alloy C4 >1.4462	Flange EN 1092-1 (DIN 2527)	5.2 kg	
	CN6**	DN80	PN25/40 B1	AlloyC22 >1.4462	Flange EN 1092-1 (DIN 2527)	5.2 kg	
	B02	DN80	PN63 A	316Ti	Flange EN 1092-1 (DIN 2527 B)	6.9 kg	
	C02	DN80	PN63 B2	316L	Flange EN 1092-1 (DIN 2527 E)	6.9 kg	
	C05	DN80	PN63	Alloy C4 >1.4462	Flange EN 1092-1 (DIN 2527)	6.9 kg	
	C06**	DN80	PN63 B1	AlloyC22 >1.4462	Flange EN 1092-1 (DIN 2527)	6.9 kg	
	B12	DN80	PN100 A	316L	Flange EN 1092-1	8.0 kg	
	C12	DN80	PN100 B2	316L	Flange EN 1092-1	8.0 kg	
	CO2	DN100	PN10/16 B1	316L	Flange EN 1092-1 (DIN 2527 C)	5.3 kg	
	BR2	DN100	PN25/40 A	316L	Flange EN 1092-1 (DIN 2527 B)	7.5 kg	
	BU2	DN100	PN63 A	316L	Flange EN 1092-1 (DIN 2527 B)	10.1 kg	
	CU2	DN100	PN63 B2	316L	Flange EN 1092-1 (DIN 2527 E)	10.1 kg	
	CU5	DN100	PN63	Alloy C4 >1.4462	Flange EN 1092-1 (DIN 2527)	10.1 kg	
	CU6**	DN100	PN63 B1	AlloyC22 >1.4462	Flange EN 1092-1 (DIN 2527)	10.1 kg	
	ANSI flanges						
	A82*	1"	150 lbs	RF	316/316L	Flange ANSI B16.5	1.0 kg
	AB2*	1¼"	300 lbs	RF	316/316L	Flange ANSI B16.5	2.0 kg
	AC2*	1½"	150 lbs	RF	316/316L	Flange ANSI B16.5	1.5 kg
	AD2*	1½"	300 lbs	RF	316/316L	Flange ANSI B16.5	2.7 kg
	AE2*	2"	150 lbs	RF	316/316L	Flange ANSI B16.5	2.4 kg
	AE5*	2"	150 lbs		Alloy C4 >1.4462	Flange ANSI B16.5	2.4 kg
	AE6**	2"	150 lbs	RF	AlloyC22 >1.4462	Flange ANSI B16.5	2.4 kg
	AF2*	2"	300 lbs	RF	316/316L	Flange ANSI B16.5	3.2 kg
	AF5*	2"	300 lbs		Alloy C4 >1.4462	Flange ANSI B16.5	3.2 kg
	AF6**	2"	300 lbs	RF	AlloyC22 >1.4462	Flange ANSI B16.5	3.2 kg
	AG2*	2"	600 lbs	RF	316/316L	Flange ANSI B16.5	4.2 kg
	AG5*	2"	600 lbs		Alloy C4 >1.4462	Flange ANSI B16.5	4.2 kg
	AG6**	2"	600 lbs	RF	AlloyC22 >1.4462	Flange ANSI B16.5	4.2 kg

20		Process connection:					Additional weight
	AL2*	3"	150 lbs	RF	316/316L	Flange ANSI B16.5	4.9 kg
	AM2*	3"	300 lbs	RF	316/316L	Flange ANSI B16.5	6.8 kg
	AN2*	3"	600 lbs	RF	316/316L	Flange ANSI B16.5	8.5 kg
	AN5*	3"	600 lbs		Alloy C4 >1.4462	Flange ANSI B16.5	8.5 kg
	AN6**	3"	600 lbs	RF	AlloyC22 >1.4462	Flange ANSI B16.5	8.5 kg
	AP2*	4"	150 lbs	RF	316/316L	Flange ANSI B16.5	7.0 kg
	AQ2*	4"	300 lbs	RF	316/316L	Flange ANSI B16.5	11.5 kg
	AR2*	4"	600 lbs	RF	316/316L	Flange ANSI B16.5	17.3 kg
		JIS flanges					
	KF2	20 K 50		RF	316L	Flange JIS B2220	1.9 kg
	KF5	20 K 50		RF	Alloy C4 >316L	Flange JIS B2220	1.9 kg
	KF6**	20 K 50		RF	AlloyC22 >316L	Flange JIS B2220	1.9 kg
	YY9	Special version					
	* With CRN approval.						
	** AlloyC22 in preparation.						
30		Probe length:					
	FTL70						
	AB	Compact version			Ra < 3.2 µm/80 grit,	316L	
		Fork: 318L					
	AE	Compact version			Ra < 3.2 µm/80 grit,	Alloy	
	FTL71						
	BB mm L			Ra < 3.2 µm/80 grit,	316L	
		Fork: 318L					0.9 kg/m
	BE mm L			Ra < 3.2 µm/80 grit,	Alloy	0.9 kg/m
	CB inch L			Ra < 3.2 µm/80 grit,	316L	
		Fork: 318L					2.3 kg/100 in
	CE inch L			Ra < 3.2 µm/80 grit,	Alloy	2.3 kg/100 in
	YY	Special version					
40		Electronics; output:					
	A	FEL50A;	PROFIBUS PA				
	1	FEL51;	SIL 2-wire		19 to 253 V AC		
	2	FEL52;	SIL 3-wire PNP		10 to 55 V DC		
	4	FEL54;	SIL relay DPDT		19 to 253 V AC/19 to 55 V DC		
	5	FEL55;	SIL 8/16 mA		11 to 36 V DC		
	6	FEL56;	SIL NAMUR (L-H signal)				
	7	FEL57;	SIL 2-wire PFM				
	8	FEL58;	SIL NAMUR + test keys (H-L signal)				
	9	Special version					
50		Housing; cable entry:					
	E1*	F27 316L		NEMA6P;		Thread NPT ¾	
	E4	F16 Polyester		NEMA4X;		Thread NPT ½	
	E5	F17 Alu		NEMA4X;		Thread NPT ¾	0.5 kg
	E7	T13 Alu		coated, IP66;		Thread NPT ¾	
		Separate connection compartment					1.1 kg
	E8	F13 Alu		NEMA4X;		Thread NPT ¾	
		Suitable for EEx d/XP					0.5 kg
	F1*	F27 316L		IP68		Thread G1/2	
	F4	F16 Polyester		IP66;		Thread G ½	
	F5	F17 Alu		IP66;		Thread G ½	0.5 kg
	F7	T13 Alu		coated, IP66;		Thread G ½	
		Separate connection compartment					1.1 kg
	F8	F13 Alu		IP68;		Thread G ½	
		Suitable for EEx d/XP					0.5 kg
	G1*	F27 316L		IP68;		M20 threaded joint	
	G4	F16 Polyester		IP66;		M20 threaded joint	
	G5	F17 Alu		IP66;		M20 threaded joint	0.5 kg
	G7	T13 Alu		coated, IP66;		M20 threaded joint	

50					Housing; cable entry:		
					Separate connection compartment (EEx d > M20 thread)	1.1 kg	
				G8	F13 Alu IP68; M20 threaded joint		
					Suitable for EEx d/XP	0.5 kg	
				N4	F16 Polyester IP66; M12 connector		
				N4	F16 Polyester IP66; M12 connector		
				N5	F17 Alu IP66; M12 connector		
				Y9	Special version		
					* F27 housing in preparation.		
60					Additional options		
				A	Basic version		
				C	EN 10204 - 3.1 material (316L/318L wetted) Inspection certificate		
				N	EN 10204 - 3.1, material NACE MR0175 (316L wetted) Inspection certificate		
				S	GL/ABS marine approval		
				Y	Special version		
70					Application:		
				L	230 °C, gas-tight feed-through		
				N	280 °C, gas-tight feed-through	0.2 kg	
				Y	Special version		
FTL7x-					Complete product designation		



Note!

The basic weight includes the compact sensor, thread adapter G 3/4, electronic insert, polyester housing

Accessories

Lap joint flange

With G 1 thread for mounting a Liquiphant S FTL70/71 with process connection GR2
 Pressure: up to 40 bar
 Material: corrosion-resistant steel 1.4301 (AISI 304)
 Weight: 0.54 kg
 Order number: 918158-0000

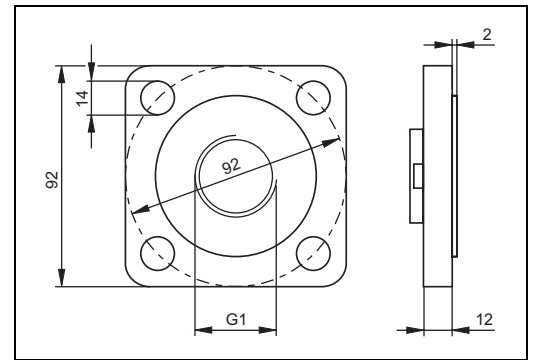

L00-FTL5xxxx-06-05-xx-xx-024

Lap joint flanges

With G 1 thread for mounting a Liquiphant S FTL70/71 with process connection GR2
 Material: corrosion-resistant steel 1.4571 (AISI 113Ti)
 – Flange DN 50, PN 40, DIN 2527 form B
 Weight: 3.11 kg
 Order number: 918143-0000
 – Flange ANSI 2", 150 psi, RF
 Weight: 2.38 kg
 Order number: 918144-0000

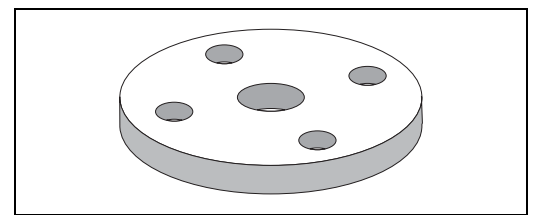

L00-FTL5xxxx-03-05-xx-xx-015

Sliding sleeves for unpressurized operation

For continuous adjustment of the switch point of a Liquiphant S FTL71.

Material: corrosion-resistant steel 1.4435 (AISI 316 L)
 Weight for G 1, NPT 1: 0.21 kg
 Weight for G 1½, NPT 1½: 0.54 kg

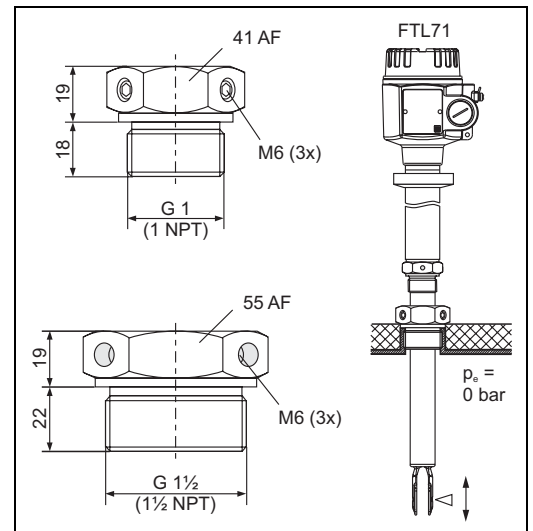

L00-FTL7xxxx-06-05-xx-en-001

Thread	Standard	Material	Order number	Approval
G 1	DIN ISO 228/1	1.4435 (AISI 316 L)	52003978	
G 1	DIN ISO 228/1	1.4435 (AISI 316 L)	52011888	3.1 inspection certificate EN 10204 - 3.1 material
NPT1	ANSI B 1.20.1	1.4435 (AISI 316 L)	52003979	
NPT1	ANSI B 1.20.1	1.4435 (AISI 316 L)	52011889	3.1 inspection certificate EN 10204 - 3.1 material
G 1½	DIN ISO 228/1	1.4435 (AISI 316 L)	52003980	

Thread	Standard	Material	Order number	Approval
G 1½	DIN ISO 228/1	1.4435 (AISI 316 L)	52011890	3.1 inspection certificate EN 10204 - 3.1 material
NPT1½	ANSI B 1.20.1	1.4435 (AISI 316 L)	52003981	
NPT1½	ANSI B 1.20.1	1.4435 (AISI 316 L)	52011891	3.1 inspection certificate EN 10204 - 3.1 material

High pressure sliding sleeves

For continuous adjustment of the switch point of a Liquiphant M FTL51.
Also for use in hazardous areas. Additional information
→ 39+. (ATEX, NEPSI).

Material: corrosion-resistant steel
1.4435 (AISI 316L) or AlloyC4/C22

Weight for G 1, NPT 1: 1.13 kg
Weight for G 1½, NPT 1½: 1.32 kg

Seal package made of graphite

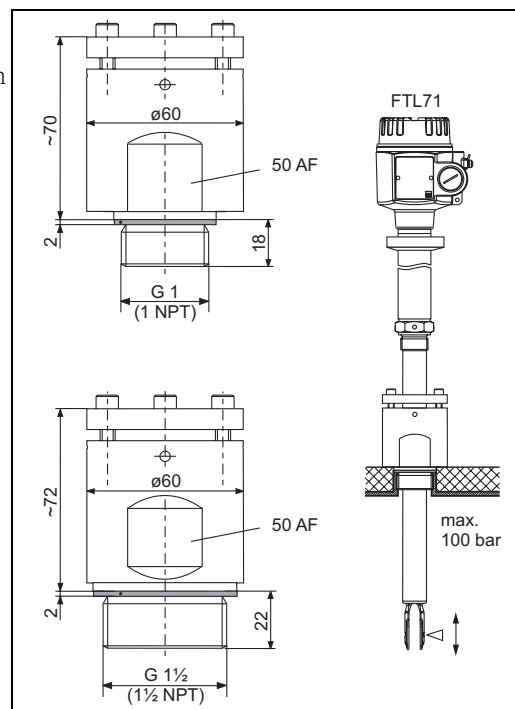

L00-FTL7xxxx-06-05-xx-en-002

Thread	Standard	Material	Order number	Approval
G 1	DIN ISO 228/1	1.4435 (AISI 316 L)	52003663	
G 1	DIN ISO 228/1	1.4435 (AISI 316 L)	52011880	3.1 inspection certificate EN 10204 - 3.1 material
G 1	DIN ISO 228/1	Alloy C4	52003664	
G 1	DIN ISO 228/1	AlloyC22	*	
NPT1	ANSI B 1.20.1	1.4435 (AISI 316 L)	52003667	
NPT1	ANSI B 1.20.1	1.4435 (AISI 316 L)	52011881	3.1 inspection certificate EN 10204 - 3.1 material
NPT1	ANSI B 1.20.1	Alloy C4	52003668	
NPT1	ANSI B 1.20.1	AlloyC22	*	
G 1½	DIN ISO 228/1	1.4435 (AISI 316 L)	52003665	
G 1½	DIN ISO 228/1	1.4435 (AISI 316 L)	52011882	3.1 inspection certificate EN 10204 - 3.1 material
G 1½	DIN ISO 228/1	Alloy C4	52003666	
G 1½	DIN ISO 228/1	AlloyC22	*	
NPT1½	ANSI B 1.20.1	1.4435 (AISI 316 L)	52003669	
NPT1½	ANSI B 1.20.1	1.4435 (AISI 316 L)	52011883	3.1 inspection certificate EN 10204 - 3.1 material
NPT1½	ANSI B 1.20.1	Alloy C4	52003670	
NPT1½	ANSI B 1.20.1	AlloyC22	*	

* AlloyC22 in preparation.

Pressure and temperature derating of the high pressure sliding sleeves

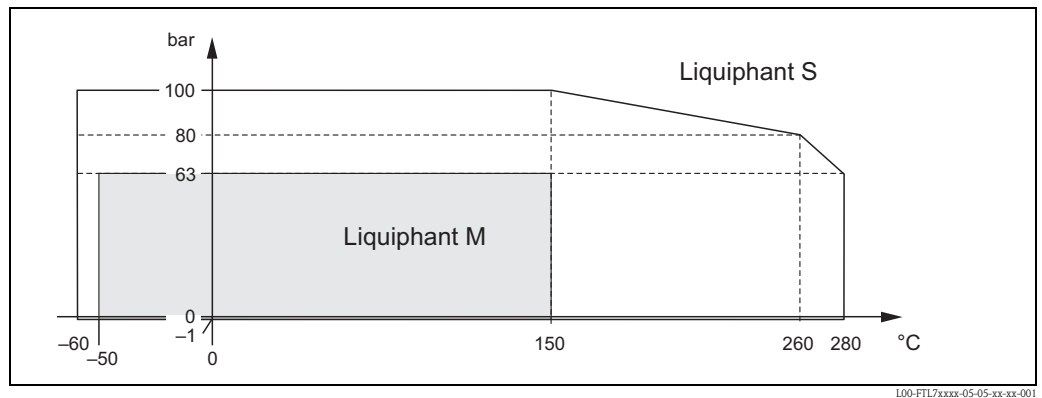

Cover with sight glass

For polyester housing
 Material: PA 12
 Weight: 0.04 kg
 Order number: 943461-0001

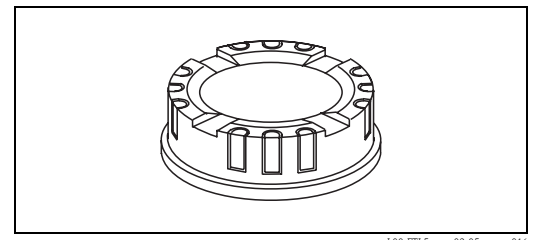

Cover with sight glass

For stainless steel housing F15
 Material: AISI 316L
 Weight: 0.16 kg
 – Order number: 943301-1000
 With glass sight glass
 – Order number: 52001403
 With PC sight glass
 (Not for CSA, General Purpose)

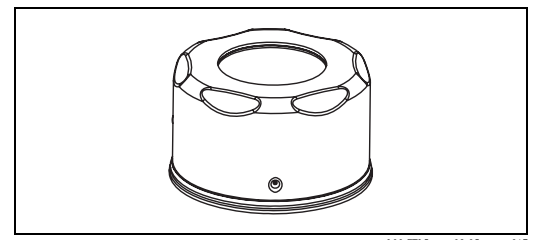

Documentation



Note!
 You can find supplementary documentation on the product pages at www.endress.com

Operating Instructions

- Electronic insert FEL50A for Liquiphant M/S
 PROFIBUS PA
 BA141F/00/en
- Liquiphant S FTL70, FTL71
 KA172F/00/a6
- Liquiphant S FTL70-##### # 7 #, FTL71-##### # 7 #
 KA173F/00/a6
- Liquiphant M/S Sliding Sleeve for FTL51/71, G 1, NPT 1
 KA151F/00/a6
- Liquiphant M/S Sliding Sleeve for FTL51/71, G 1½, NPT 1½
 KA152F/00/a6
- Liquiphant M/S High-pressure Sliding Sleeve for FTL51/71, G 1, NPT 1
 KA153F/00/a6
- Liquiphant M/S High-pressure Sliding Sleeve for FTL51/71, G 1½, NPT 1½
 KA154F/00/a6

Technical Information

Nivotester FTL370/372, switching units in Racksyst design
for Liquiphant S with electronic insert FEL57
TI198F/00/en

Nivotester FTL320, switching unit in Minipac design
for Liquiphant S with electronic insert FEL57
TI203F/00/en

General instructions for electromagnetic compatibility
(Test procedure, installation recommendation)
TI241F/00/en

Isolating amplifier FTL325P, 1 or 3-channel switching units for top-hat rail mounting
for Liquiphant M/S with electronic insert FEL57
TI350F/00/en

Isolating amplifier FTL325N, 1 or 3-channel switching units for top-hat rail mounting
For Liquiphant M/S with electronic insert FEL56, FEL58
TI353F/00/en

Liquiphant M FTL50/51(H), for process temperatures up to 150 °C
TI328F/00/en

Isolating amplifier FTL375P, 1 to 3-channel switching units for top-hat rail mounting
for Liquiphant M/S with electronic insert FEL57
TI360F/00/en

Isolating amplifier FTL375N, 1 to 3-channel switching units for top-hat rail mounting
For Liquiphant M/S with electronic insert FEL56, FEL58
TI361F/00/en

Functional safety (SIL)

Liquiphant M/S with electronic insert FEL51 (MAX)
SD164F/00/en

Liquiphant M/S with electronic insert FEL51 (MIN)
SD185F/00/en

Liquiphant M/S with electronic insert FEL52 (MAX)
SD163F/00/en

Liquiphant M/S with electronic insert FEL52 (MIN)
SD186F/00/en

Liquiphant M/S with electronic insert FEL54 (MAX)
SD162F/00/en

Liquiphant M/S with electronic insert FEL54 (MIN)
SD187F/00/en

Liquiphant M/S with electronic insert FEL55 (MAX)
SD167F/00/en

Liquiphant M/S with electronic insert FEL55 (MIN)
SD279F/00/en

Liquiphant M/S with electronic insert FEL57 + Nivotester FTL325P (MAX)
SD111F/00/en

Liquiphant M/S with electronic insert FEL57 + Nivotester FTL325P (MIN)
SD231F/00/en





Liquiphant M/S with electronic insert FEL57+ Nivotester FTL375P (MAX)
SD113F/00/en

Liquiphant M/S with electronic insert FEL56 + Nivotester FTL325N (MAX)
SD168F/00/en

Liquiphant M/S with electronic insert FEL56 + Nivotester FTL325N (MIN)
SD188F/00/en

Liquiphant M/S with electronic insert FEL58 + Nivotester FTL325N (MAX)
SD161F/00/en

Liquiphant M/S with electronic insert FEL58 + Nivotester FTL325N (MIN)
SD170F/00/en

Safety Instructions (ATEX)	<p> CE  II 1/2 G, EEx d IIC/B (KEMA 99 ATEX 1157) XA031F/00/a3 </p> <p> CE  II 1/2 G, EEx ia/ib IIC/B (KEMA 99 ATEX 0523) XA063F/00/a3 </p> <p> CE  II 1 G, EEx ia IIC/B (KEMA 99 ATEX 5172 X) XA064F/00/a3 </p> <p> CE  II 1/2 G, EEx de IIC/B (KEMA 00 ATEX 2035) XA108F/00/a3 </p> <p> CE  II 3 G, EEx nA/nC II (EG 01 007-a) XA182F/00/a3 </p>
Safety Instructions (NEPSI)	<p> Ex d IIC/IIB T3-T6 , Ex d IIC T2-T6 (NEPSI GYJ06424) XA401F/00/B2 </p> <p> Ex ia IIC T2-T6, Ex ia IIB T3-T6 (NEPSI GYJ05556, NEPSI GYJ06464), XC009F/00/b2 </p> <p> Ex nA II T3-T6, Ex nC/nL IIC T3-T6 (NEPSI GYJ04360, NEPSI GYJ071414) XC010F/00/b2 </p>
Control Drawings	<p> Liquiphant M/S (IS and NI) Current output PFM, NAMUR Entity installation Class I, Div. 1, 2, Groups A, B, C, D Class I, Zone 0 Class II, Div. 1, 2, Groups E, F, G Class III ZD041F-I/00/EN </p> <p> Liquiphant M, Liquiphant S (cCSAus / IS) Class I, Div. 1, Groups A, B, C, D Ex ia IIC T6 Class II, Div. 1, Groups E, F, G Class III ZD042F-G/00/EN </p> <p> Liquiphant M/S (NI), FTL50(H), FTL51(H), FTL51C, FTL70, FTL71 Class I, Div. 2, Groups A, B, C, D Class II, Div. 2, Groups F, G Class III ZD043F-C/00/EN </p> <p> Liquiphant M, Liquiphant S (cCSAus / XP) Class I, Groups A, B, C, D Class II, Groups E, F, G Class III ZD240F/00/EN </p> <p> Liquiphant M/S (IS and NI) PROFIBUS PA, FOUNDATION Fieldbus Class I, Division 1, 2, Groups A, B, C, D Class II, Division 1, 2, Groups E, F, G Class III ZD244F/00/EN </p>
System information	<p> Liquiphant family SI040F/00/en and CP009/00/en </p>

Instruments International

Endress+Hauser
Instruments International AG
Kaegenstrasse 2
4153 Reinach
Switzerland

Tel. +41 61 715 81 00
Fax +41 61 715 25 00
www.endress.com
info@ii.endress.com

Endress+Hauser 
People for Process Automation

