

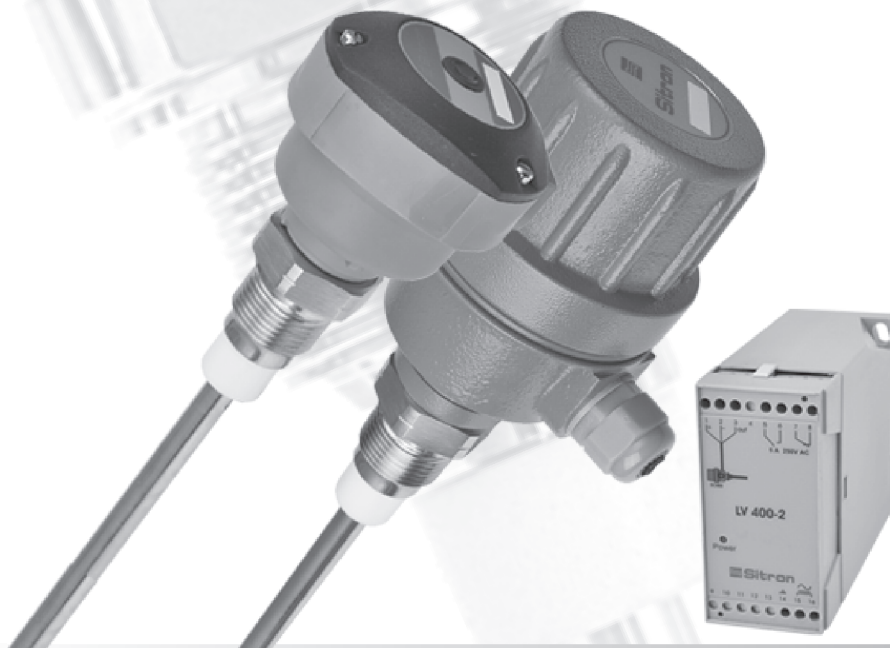

USER'S GUIDE

Installation, Operation, Maintenance Instructions



## SC400 & LV400

Capacitive Point Level Sensor

## Contents

Introduction . . . . .	3
Models & Dimensions . . . . .	4
Wiring Diagram . . . . .	5
Installation . . . . .	9
Calibration . . . . .	11
Handling . . . . .	12
Technical Specifications . . . . .	13
Trouble Shooting . . . . .	14
Ordering Information . . . . .	15
Terms & Conditions . . . . .	16

### **SC400 - Capacitive Point Level Sensor + LV400 - Relay Controller**



The SC400 Series, together with the LV400 Relay Controller are designed to detect the level of a wide variety of solids and liquids, including both conductive and non-conductive materials.

Because of its all 316SS construction the SC400 is typically specified for high temperature or high pressure applications, or for applications requiring extremely high mechanical resistance in such products as cement, sand, coal, grains, etc. When supplied with Halar or PTFE tubed rod, the SC400 can be applied in corrosive or aggressive mediums.

Made of 316 Stainless Steel, the SC400 is available with various types of process connections such as threaded, flange or sanitary. Custom connections available upon request.

The controller LV400 can be ordered for varying supply voltages; 24Vdc, 110Vac or 220Vac with an SPDT relay output.

#### **Features**

- Wide range of applications/industries:  
I.e. water, oils, corrosives, solids, powders, grains, etc.
- Accurate and reliable measurement
- No moving parts - Rugged construction
- Can operate at high temperatures and pressure
- Functions on conductive as well as non-conductive medias

# Models & Dimension

## Mounting Options for SC400

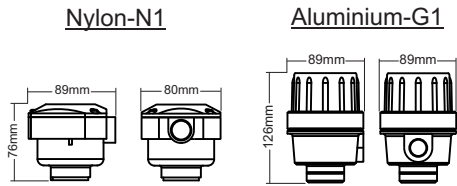

## Extended Necks for High Temperature



Extended necks for medium temperature (up to 120°C) and high temperature (up to 150°C)

### SC400 Standard

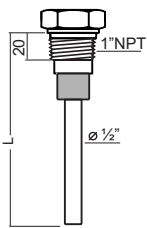

L = Insertion length

### Relay Controller LV400

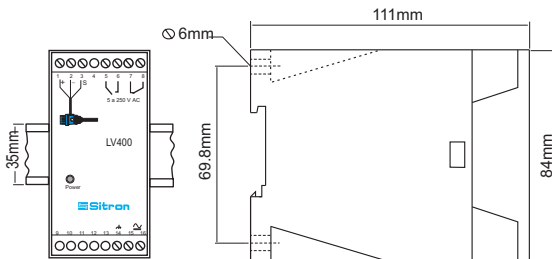

**Note:** Insertion Lengths greater than 150mm will require the balance to be ordered with a non-active portion of that insertion length. This can affect how certain types of coatings can be ordered with this model.

## Process Connections

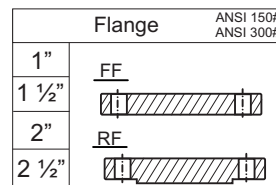
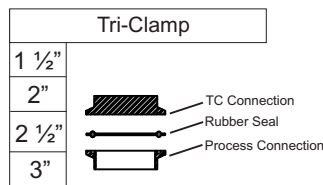
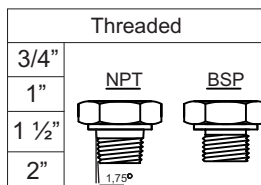

# Wiring Diagram

## SC400 - N1 Housing

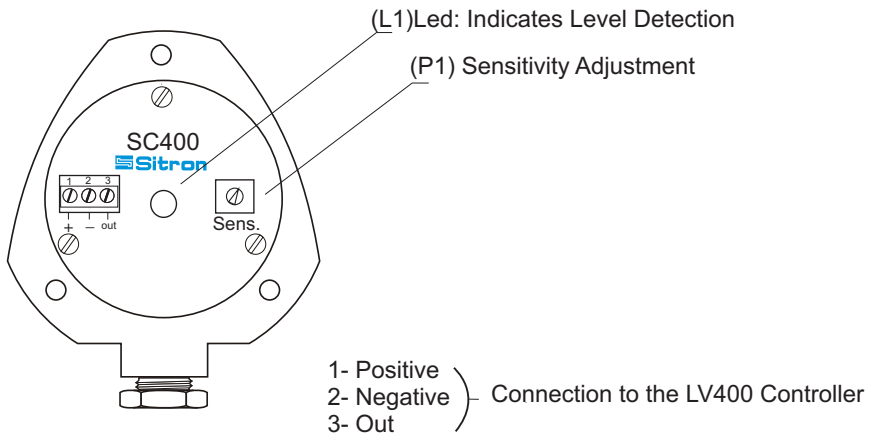

---

## SC400 - G1 Housing

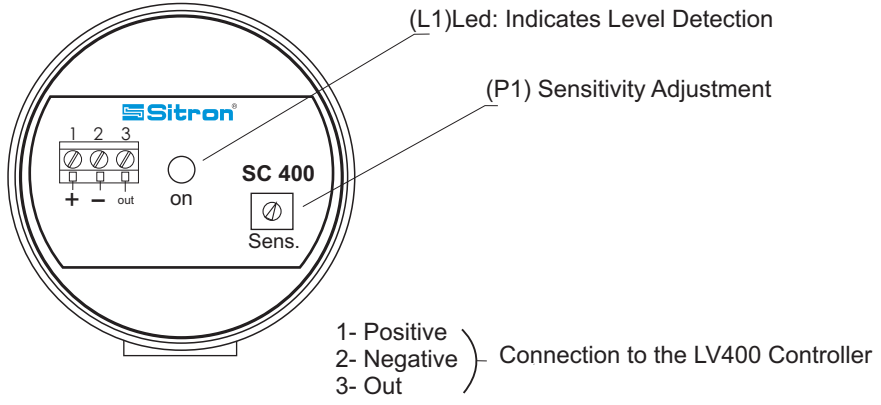

## Wiring Diagram

### SC400 - G1 Housing

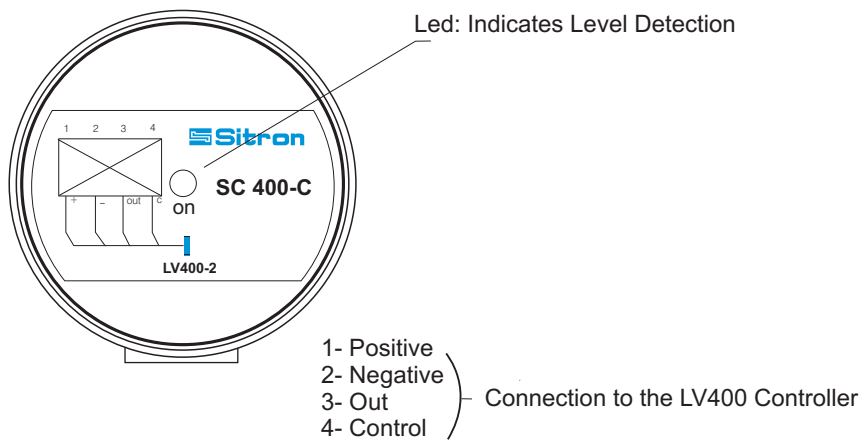

## Wiring Diagram

### LV400 Controller & SC400 Probe

Note: The SC400 series works in conjunction with the LV400 Relay controller and will not work without it.

### Sensitivity adjustment by SC400

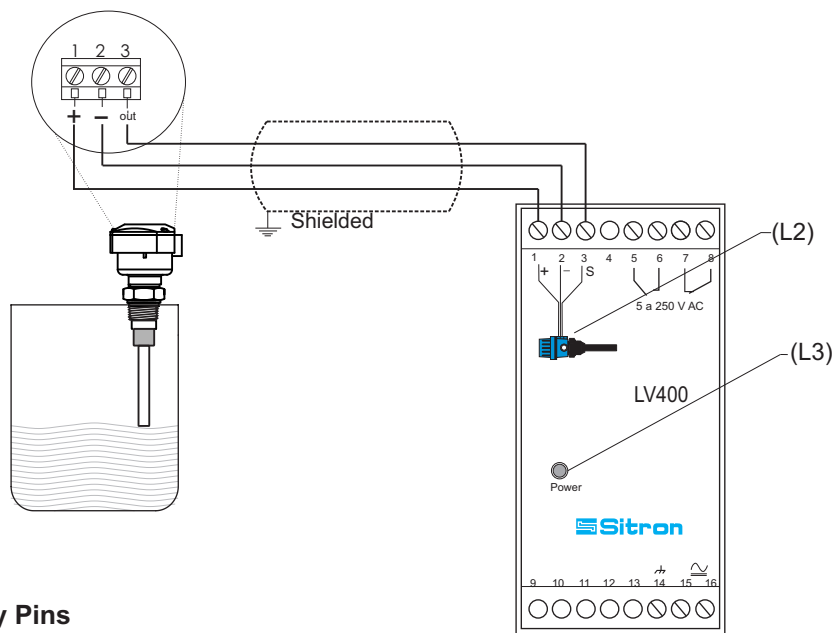

### Relay Pins

- 1- )
- 2- ) Input (Probe)
- 3- )
- 5- Contact NO
- 6- Common
- 7- Common
- 8- Contact NC
- 14- Ground
- 15- Power Supply ( $\sim$ )(-)
- 16- Power Supply ( $\sim$ )(-)
- L2- Led: Level Indication
- L3- Led: Power

## Wiring Diagram

### LV400 Controller & SC400 Probe

Note: The SC400 series works in conjunction with the LV400 Relay controller and will not work without it.

### Sensitivity adjustment by LV400 Controller

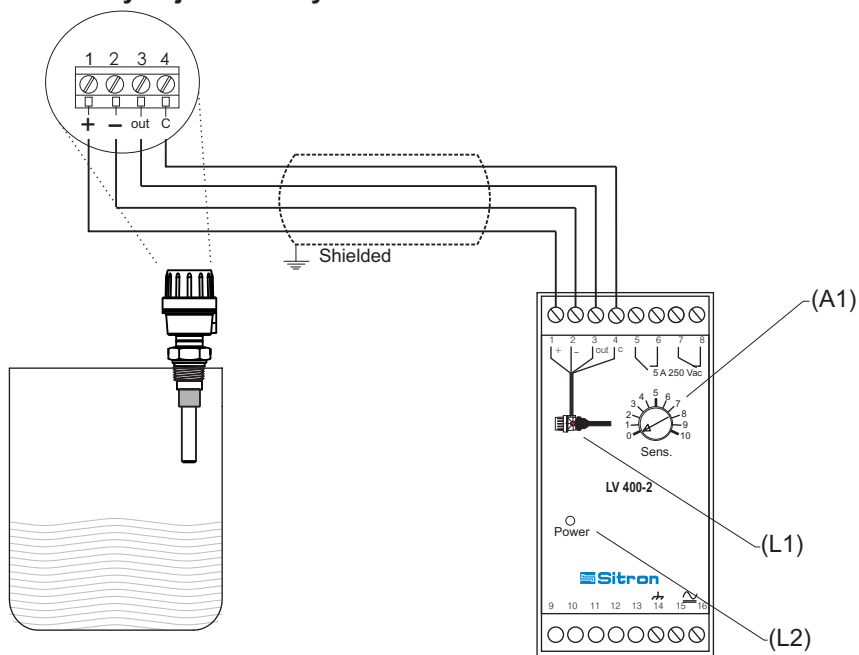

### Relay Pins

- 1- )
- 2- ) Input (Probe)
- 3- )
- 4- Input signal (Sensitivity control)
- 5- Contact NO
- 6- Common
- 7- Common
- 8- Contact NC
- 14- Ground
- 15- Power Supply ( $\sim$ )(-)
- 16- Power Supply ( $\sim$ )(-)
- L1- Led: Level indication
- L2- Led: Power indication
- A1- Sensitivity adjustment



## Installation

When making connections between the controller and the probe use reliability cables and make sure they are grounded.

Shielded cables prevent interference and changes in electronic

Improving and protecting against false measurements.

To avoid radio frequency interference and possible malfunction. When possible, keep hand held communication equipment away from the SC400 and LV400. If this unavoidable make a metal shield around the the flow switch and confirm that the unit has been properly grounded

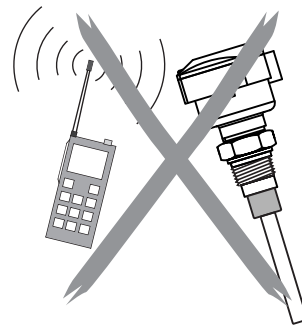

Do not install the controller in harsh environments and humid. Respect class protection, working temperature and protect the same from rain and excessive heat.

A stable Power Supply prevents burning and equipment malfunction.

### Controller Mounting

Panel mounting with the protection cover

A- DIN rail (35mm)

B- Screws

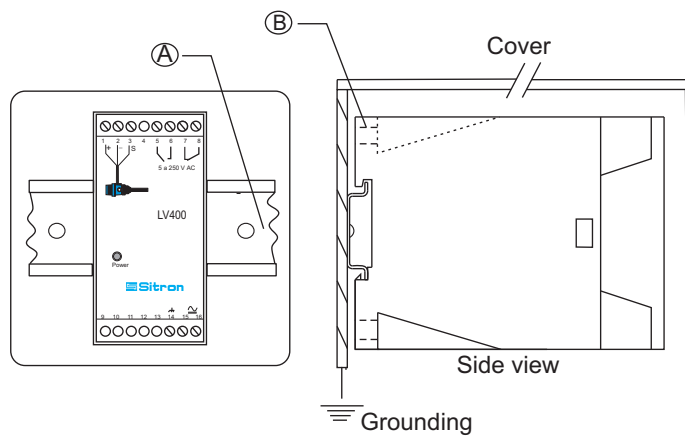

## Installation

Verify that the location the probe is to be mounted is not directly in the path of the product as it enters the vessel. (Fig. 1)

When installing more than one probe, verify that they are separated by a minimum distance of 500mm. (Fig. 1)

Material falling onto the probe can cause damage or switching errors. If this is unavoidable, it is recommended that a protective shield be installed above the probe. The shield is also recommended when the probe is used for a low level switch or in the outflow of the product. (Fig. 2)

The tip of the probe should point slightly downward (when possible) so that if there is any excess of product it will easily slide from the probe. (Fig. 2)

When installing from the top of the tank confirm that the tip of the probe has cleared the side of the vessel at least 500mm. (Fig. 3)

When installing the sensor directly to the tank make sure that the rod extends beyond the inner wall of the tank, by as much as possible, so that internal build up or other debris does not interfere with the sensor's performance. (Fig. 2 correct Fig. 4 incorrect)

Ensure that the conduit is facing downward so that water does not enter the housing from the cable entry point. (Fig. 5)

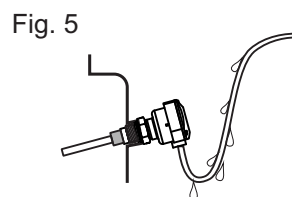
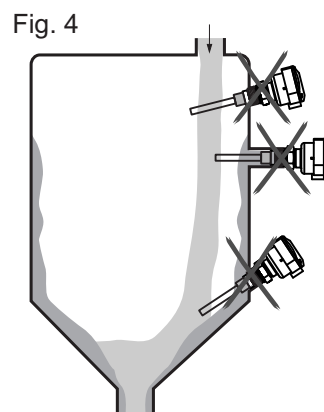
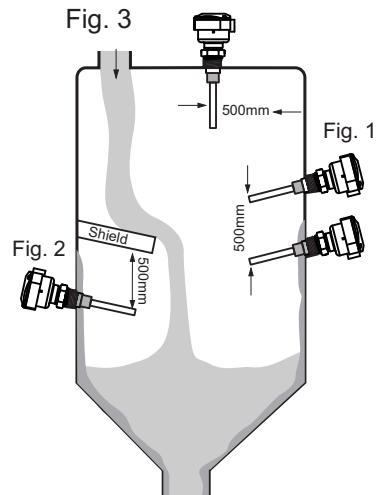

## Calibration

### Calibration

1. Install the probe and power it on. The green LED (L3) on the controller should be on.
2. Turn the potentiometer (P1) counter-clockwise (Fig.1) before the tank is filled.
4. Fill the tank until the probe is in contact with the medium.
5. Turn the potentiometer clockwise until the LED (L1) of the probe and the red LED (L2) on the controller are on. (Fig.2)

Products with a low dielectric constant may require most or all of the active length of the probe to be covered by the product before the controller activates the relay.

Fig.1

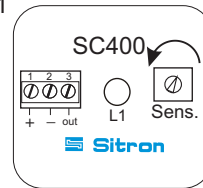
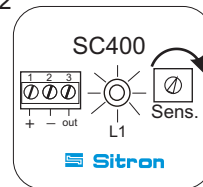

Fig.2



### Relay

Fig.1

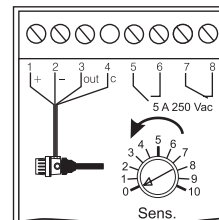
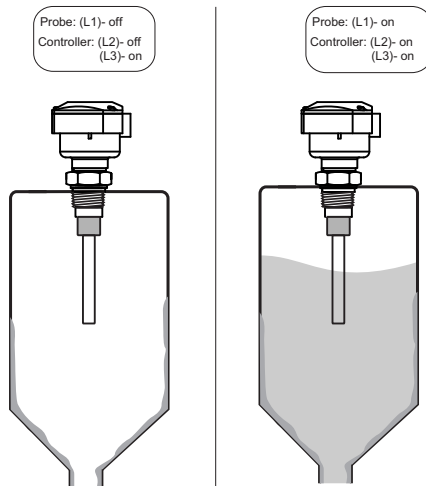
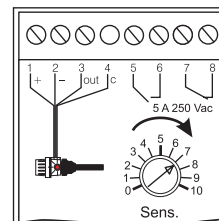

Fig.2



## Probes:

Seal the thread with Teflon tape before installation (Fig. 1).

Fig. 1

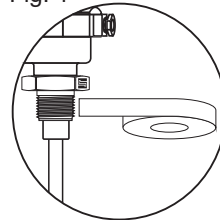

Do not turn or handle by the housing (Fig. 2).

Fig. 2

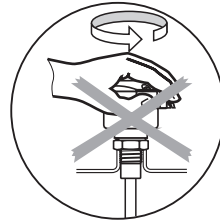

When tightening the sensor, use only use the 316S.S. hexagon fitting to achieve a seal, do not twist with the body of the sensor. (Fig. 3)

Fig. 3

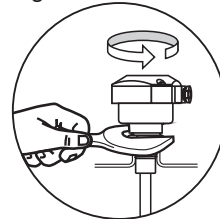

The probe should not be dropped or suffer any impact or fall that could damage the electronics or the coating of the probe (Fig. 4 and 5).

Periodic visual inspection of the probe is required to check for corrosion or deposit build-up. If deposits are found, clean the sensor to ensure optimum performance.

Fig. 4

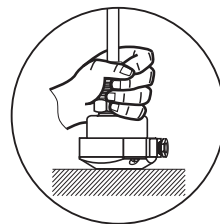

Care should be taken when handling and installing probes with coated rods to avoid scratching them. Scratching the coating could interfere with the probe performance.

Fig. 5

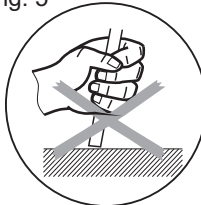

When cleaning the rod use a soft brush or rag.

## Technical Especification

### SC400 + LV400

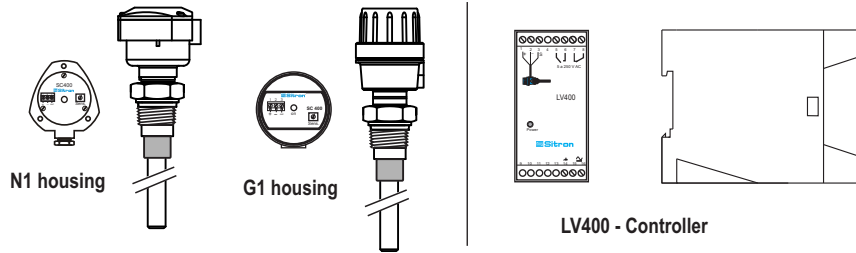

Application	Level Detection for Solids and liquids.
Power Supply	LV400: 24Vdc (+/- 10%) 110 or 220Vac (50/60Hz)
Consumption	2VA
Adjustment	Sensibility
Sensitivity	0 to 5pF
Level Indication	LED ON/OFF
Output	Relay (SPDT) 5A-250Vac
Electrical Connection	Cable Gland - 1/2" NPT or M12 connector
Process Connection	3/4" to 1 1/2" BSP or NPT Flange or Sanitary
Wetted Parts	316SS, PTFE or Halar Coated
Enclosure	Relay : ABS ( Resistant thermoplastic)
Housing	Nylon Fiberglass (Optional Aluminum)
Max. Pressure	290 PSI (20 Bar)
Operating Temperature	Probe: (-10 to 120°C) / Controller -10 to 60°C
Class Protection	Probe: IP 65 / Controller: IP40

## Trouble Shooting

Fail	Cause	Solution
Relay does not work	LED off, without Power Supply	Check the Power Supply
	Lack of signal from SC400	Verify the connections
	Low sensitivity	Adjust sensitivity with the potentiometer
Relay does not turn off	Coating on the rod is damaged	Consult for repair or replacement
	Material Build-up on the rod	Clear the rod

# Ordering Information

<b>MODEL</b>	
SC400	
<b>SIZE</b>	
4	3/4"
5	1"
6	1 1/2"
7	2"
9	3"
Q	4"
X	OTHER
<b>PROCESS CONNECTION TYPE</b>	
B	BSP
D	FLANGE ANSI 150# CARBON STEEL PAINTED
E	FLANGE ANSI 150# 316 SS
G	FLANGE ANSI 300# CARBON STEEL PAINTED
H	FLANGE ANSI 300# 316 SS
K	FLANGE ANSI 150# - 304 SS
L	FLANGE ANSI 300# - 304 SS
N	NPT
S	SAE O'RING - 316SS
T	TRI CLAMP
X	OTHER SPECIFY
<b>TYPE OF ROD</b>	
C	ROD & SHEATH 316SS 1/2"(12,7mm)
R	ROD - 316SS 1/2"(12,7mm)
IA	INACTIVE + ACTIVE
<b>COATING</b>	
S	NONE
E	EPOXY ( up to 120°C)
H	COATED HALLAR ( up to 150°C)
M	COATED PTFE ( up to 260°C)
P	PEEK ( up to 260°C)
T	PTFE TUBED
X	OTHER - SPECIFY
<b>INSERTION LENGTH</b>	
L	SPECIFY
<b>HOUSING</b>	
N1	SMALL NYLON
G1	SMALL ALUMINIUM
<b>ELECTRICAL CONNECTION</b>	
1	1/2" BSP
2	CABLE GLAND W/ 1/2" BSP
4	3/4" BSP
5	CABLE GLAND W/ 3/4" BSP
6	1/2" NPT
7	CABLE GLAND W/ 1/2" NPT
9	3/4" NPT
C	CABLE GLAND W/ 3/4" NPT
<b>OPTIONS</b>	
MT	Medium Temp - 50mm 316SS Neck (80-120°C)
AT	High Temp - 100mm 316SS Neck (80-150°C)
HT	Highest Temp - 100mm + Coil 316SS Neck ( 80-200°C)
ST	316SS Tag

<b>MODEL</b>	
LV400/2-24	Power Supply: 24Vcc (+/- 10%) - Out: 1NO + 1NC
LV400/2-11	Power Supply: 110Vca (50/60Hz) - Out: 1NO + 1NC
LV400/2-23	Power Supply: 230Vca (50/60Hz) - Out: 1NO + 1NC



### Sitron's TERMS & CONDITIONS

**Design:** Sitron reserves the right to make any alterations or changes necessary to improve the Products, correct defects or to make the Products safer, without prior notice or consent by Buyer.

**Pricing:** All stipulated amounts shall be in US dollars and all prices quoted are valid for thirty (30) days from date of offer, unless otherwise stated.

**Safety and Instructions:** The Buyer ensures that it and all its representatives and agents will observe all safety and technical instructions in Sitron's operating manuals, catalogs or other directions or instructions (either written or verbal).

**Delivery and Freight:** All goods are sold FOB point of shipment, Brasil. Transportation to the destination is the Buyer's responsibility and Buyer alone shall bear the cost of freight, optional or other shipping requirements, and or insurance. Sitron shall not be liable for loss or damage to the Products after said Products are delivered to or received by the shipper/carrier, and all risk of damage or loss shall immediately pass to Buyer.

Receiving, unloading and storing of Products will be the responsibility of the Buyer.

Buyer also accepts that courier may choose to return Products to Sitron if any local taxes or duties are not paid by Buyer at point of delivery. Buyer must make any and all claims for corrections or deductions within ten days of the delivery of the Products.

**Shipment Delays:** Sitron has no control over the length of time shipments may be held at customs, etc. For this reason, Sitron commits only to a "shipment date", not a "delivery date". Buyer shall not hold Sitron liable for claims resulting from delay in shipment except in cases where these terms are accepted in writing by Sitron. Acceptance of delivery of Products by Buyer shall constitute a waiver of all claims for delay.

**Partial Deliveries:** While Sitron strives to deliver all orders on time and complete, Sitron reserves the right to make partial deliveries when necessary.

**Changes:** Any changes initiated by the Buyer which affects the products specifications; quantities ordered; delivery schedule; method of shipment or packing; or delivery location, must be made in writing and signed by both parties.

In this case, Sitron reserves the right to adjust the pricing and or delivery of the order, which will be agreed to by both parties before further work is performed on the order. Any such requests will be priced according to the scope of changes and the status of the current order. Customer must sign and return or acknowledge approval of drawings along with any Purchase Order. If approval drawings are not returned with order, the delivery date may be held or pushed back until Customer has acknowledged approval.

**Cancellation:** Any cancellation of the Contract by the Buyer shall be effective only if made in writing and accepted, in writing by the Sitron. In such a case, Sitron is entitled to reasonable cancellation charges including but not limited to labor, material and other related expenses.



## Terms & Conditions

**Termination Fee Schedule:**

Order entered but not released for manufacturing	10%
Order in any stage of production	75%
Order complete and ready for shipment	100%

**Warranty:** Sitron warrants its product against manufacturing defects in material and workmanship, when installed in applications approved by Sitron, for a period of one year from the date of original shipment, unless otherwise stated in writing by Sitron.

Sitron is not responsible for damage to Sitron's Products or other equipment or products because of improper installation or misapplication of the Products by Buyer. Installation or startup of Sitron's equipment must be performed under the guidelines set forth in Sitron's instruction manuals, wiring diagrams, etc., or performed under the direct supervision of Sitron's field technicians or Sitron's authorized Sales Representatives, in order to be covered by Sitron's warranty.

Sitron shall be under no liability in respect to any defect from fair wear and tear, willful damage, negligence, abnormal working conditions, failure to follow Sitron's instructions (whether written or verbal), misuse, modification or alteration or attempted repair of the Goods without Sitron's approval.

Sitron shall not be liable under the above warranty (or any other warranty, condition or guarantee) if the total price for the Products or the payment of Services rendered has not been paid by the due date for payment.

The Buyer must make all tools, resources or personnel available to help Sitron to diagnose the defect without any back charge. In absence of Buyer's cooperation in this regard, there shall be no liability under the above Warranty.

Sitron's liability under this warranty shall be limited to repair or replacement at Sitron's option of such defective Products, FOB factory, upon proof of defect satisfactory to Sitron. Warranty does not include transport.

**Return Goods:** No goods may be returned without Sitron's permission and an RMA number. Sitron assumes no responsibility for return shipments made without permission. In issuing credit for such shipments, Sitron reserves the right to charge a restocking fee dependent on Sitron's ability to recondition and resell the returned equipment.

**Insurance:** The responsibility for insuring the Goods after the risk in them has passed to the Buyer shall be that of the Buyer.

**Confidential Information:** All drawings, specifications, and technical information provided by either Buyer or Sitron shall be treated as confidential and shall not be disclosed to anyone other than those who require it as part of the fulfillment of the order. Buyer agrees that the designs and/or any other related material provided are and remain Sitron's exclusive property and that the Buyer acquires no right, title or interest to this intellectual property, whether in whole or in part.

**Errors:** Sitron reserves the right to correct all typographical or clerical errors or omissions, in its prices or specifications.



rev\_06\_2015

Sitron - Brasil  
R. Baronesa de Itu, 83  
São Paulo - SP - 01231-001  
T.: (5511) 3825-2111  
F.: (5511) 3825-2171

Sitron - USA  
1800 Prime Place  
Hauppauge, NY 11788  
PH: 516-935-8001  
FX: 800-516-1656

[www.sitron.com](http://www.sitron.com)  
BRASIL: [vendas@sitron.com](mailto:vendas@sitron.com)  
USA / Other Countries: [info@sitron.com](mailto:info@sitron.com)