



## Accurate Temperature Measurement in the Roadstone Industry

Today's roadstone plants are facing ever increasing demands for tighter quality control and many have now introduced quality assurance schemes to ensure that material leaving the site is within specification. The temperature of the material, both during production and prior to leaving the site is measured as part of this quality requirement. Temperature measurement of the material during production can improve the control of the process and give significant savings in energy costs.

Temperature measurement using thermocouples are not recommended because the slow response time introduces lags in the system, which ultimately results in poor control. Damage and wear caused by being in contact with the product means that thermocouples are unreliable and have constantly to be replaced.

Land developed non contact infrared thermometers for this application and have over 30 years experience in the roadstone industry. The RT8A with its linear, industry standard 4 to 20mA output signal, interfaces with all types of low cost indicators, controllers and recorders.

RT8A thermometer features and benefits:

- Faster response.
- No interference with the material or process, or damage to the measuring system.
- Accurate, reliable and stable temperature measurement to aid product quality control.
- Saves energy and heating costs.
- Maximizes production rates.

The RT8A thermometer can be used on all roadstone applications.

- Drier exit chute for measurement and control of aggregate temperature.
- Mixed material temperature in the mixer.
- Coated roadstone mixer/storage bin end.
- Drum mix plant, coated material temperature at the collector box (drum exit).

When the RT8A is used in the roadstone industry a standard 12 month warranty is offered.

# LAND

**Non-Contact Temperature  
Measurement Solutions**

An **AMETEK** Company

### Land Instruments International Ltd

Dronfield S18 1DJ, England • Tel: +44 (0) 1246 417691  
Email: land.infrared@ametek.co.uk • [www.landinst.com](http://www.landinst.com)

### AMETEK Land, Inc.

150 Freeport Rd., Pittsburgh, PA 15238, U.S.A. • Tel: +1 412 826 4444  
Email: irsales@ametek.com • [www.ametek-land.com](http://www.ametek-land.com)

For full details of all international offices and distributors please visit our websites

### Drier Exit Chute

The RT8A thermometer sights onto a stream of aggregate at the exit chute. The thermometer output can either be used to indicate aggregate temperature, or utilised in a closed loop control system to control the burner, thus minimising fuel wastage and maximising efficiency whilst controlling aggregate temperature.

### Mixing Material (Batch Heaters)

Due to the batch nature of the mixing process, automatic burner control is not possible, but knowledge of the hot stone temperature and its subsequent effect on the binder and filler temperature is a useful aid to process control. Once the material is in the mixer it is not possible to make adjustments to its temperature. Measurement here does however permit rejection of a single batch if it falls outside the temperature specification limits - avoiding contamination of acceptable material.

### Coated Roadstone Mixer Exit

Installing an RT8A thermometer at the exit of the mixer gives an accurate temperature reading of the coated roadstone prior to leaving the plant. If however, the finished product does not meet specification, there is still time to reject it. The temperature of each batch can then be recorded on a chart or stored to a computer system. The RT8A Thermometer is positioned to sight onto the stream of coated roadstone, as it falls from the mixer/storage bin into the delivery vehicle.

### Drum Mix Asphalt Plants

Modern drum-mix asphalt plants are capable of a high level of continuous production, any slight fluctuation in final mix temperature can result in batch rejection. The RT8A is mounted to sight on the stream of coated material as it leaves the discharge chute, prior to the elevator system. The thermometer output can also be fed into a chart recorder or linked to an automatic burner control system using a suitable controller.

### SCHEMATIC DIAGRAM

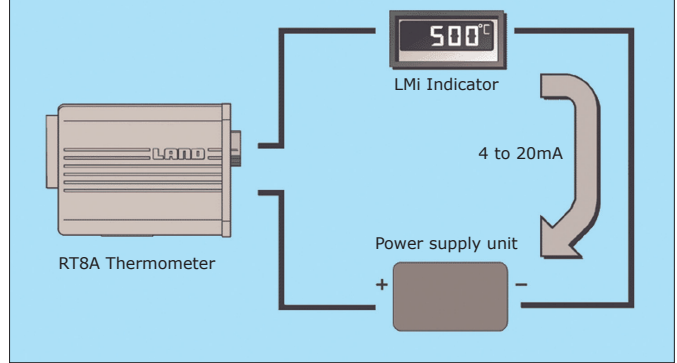

### TARGET SIZE DIAGRAM

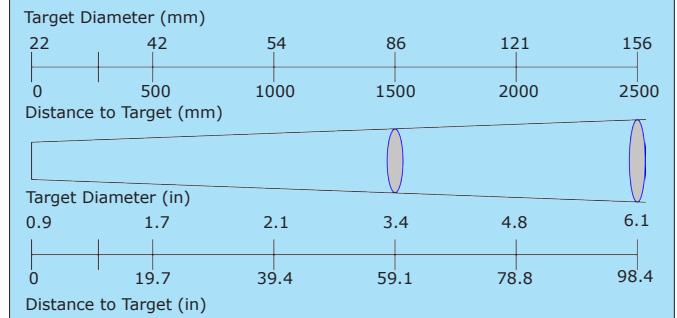

### DIMENSIONS

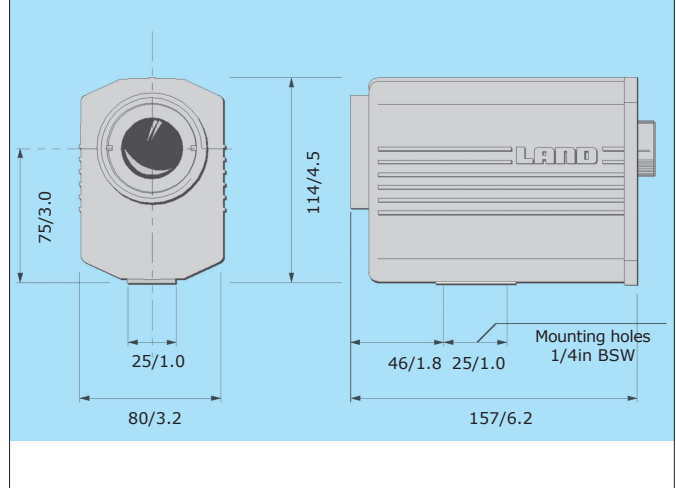

### MOUNTINGS & ACCESSORIES

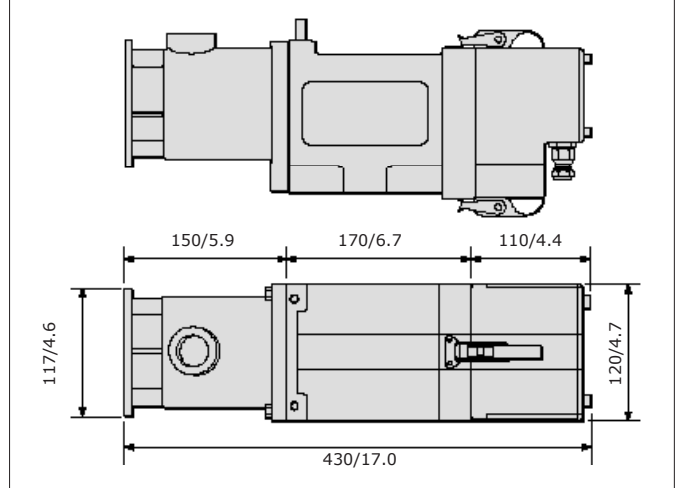

### RT8A SPECIFICATION

Measurement range	Operating	Specified*
RT80A	0 to 250°C	0 to 250°C
RT81A	0 to 500°F	30 to 500°F
RT82A	0 to 500°C	0 to 500°C
RT83A	0 to 1000°F	30 to 1000°F
Spectral response:	8 to 14µm (nominal)	
Output:	4 to 20mA, 2-wire loop connection	
Emissivity adjustment:	0.10 to 1.09 in 0.01 increments	
Response time:	1 to 10s adjustable (0 to 95%)	
Resolution:	<0.1°C/0.2°F	
Accuracy (absolute):	<0.5% of span*	
Ambient temp. limits:	-5 to 50°C/23 to 122°F (specified), -5 to 70°C/23 to 159°F (operating)	
Drift with ambient temp.:	≤1.5°C per 10°C/≤1.5°F per 10°F	
Drift with time:	<1°C/2°F per year	
Power supply:	11 to 45V d.c., 2-wire loop connection	
Load resistance:	1Kohm max.	
Vibration:	3G any axis, 10 to 300Hz	
EMC:	EN 50081-1 (emissions), EN 50082-2 (immunity), EN 61010-1 (electrical safety)	
Sealing:	To requirements of IP65/NEMA4X	
Weight:	1.4kg/3.0lb	

\*Within specified measurement range