



# Alvium

## 1500 C-050

- PYTHON 480 CMOS sensor
- ALVIUM image processing
- MIPI CSI-2 interface
- Various hardware options

## Embedded vision CSI-2 camera with PYTHON 480 sensor

Alvium CSI-2 cameras enable new designs for embedded applications with improved image quality and reduced workload for the host. The innovative ALVIUM System on Chip (SoC) performs image corrections and preprocessing tasks onboard the camera instead of the embedded board. Unlike FPGAs commonly used in machine vision cameras, the ALVIUM SoC is extremely power efficient. With Alvium, integrating hardware and software can be done effortlessly, which ultimately reduces development time. The ON Semi PYTHON 480 CMOS sensor enables high frame rates in global shutter mode. Color models ship with an IR cut filter, monochrome and S-Mount models ship without a filter or protection glass.

### Benefits and features

- Monochrome (1500 C-050m) and color (1500 C-050c) models
- ALVIUM® Technology for on-board image processing
- MIPI CSI-2 interface with up to 4 lanes
- Platform concept that enables the operation of different Alvium camera models with a common software
- Hirose HR FHH55 FPC connector with minimum space requirements for a compact design
- Precise sensor-to-lens mount alignment
- Standard M3 mounting holes for top and bottom mounting, standard M2 mounting holes for front mounting
- Industrial performance for embedded vision applications
- Easy-to-install [driver and code examples](#)

### Hardware options

- Housing: Alvium 1500 C cameras are available as bare board or open housing cameras.
- Various lens mounts: Select between S-Mount, CS-Mount, or C-Mount.



For more information on hardware options, including product codes and technical data, such as technical drawings and mass, see the [Alvium Cameras Hardware Options](#) document.

### Available accessories

- Tripod adapter
- Adapter boards for Nitrogen6\_MAX and Wandboard i.MX6
- FPC cables in 120 mm, 220 mm, and 420 mm length
- Various lenses and Allied Vision S-Mount lenses with focal lengths 2.97 - 12 mm

## Specifications

<b>Alvium</b>	<b>1500 C-050</b>
Interface	MIPI CSI-2, up to 4 lanes
Resolution	808 (H) × 608 (V)
Spectral range	300 to 1100 nm
Sensor	ON Semi PYTHON 480
Sensor type	CMOS
Shutter mode	Global shutter
Sensor size	Type 1/3.6
Pixel size	4.8 μm × 4.8 μm
Lens mounts (available)	CS-Mount, C-Mount, S-Mount
Max. frame rate at full resolution	116 fps using 1 to 4 lanes, RAW8
ADC	10 Bit
Image buffer (RAM)	256 KB
Non-volatile memory (Flash)	1024 KB
<b>Output</b>	
Bit depth	Max. 10 Bit
YUV color pixel formats	YUV422_10
RGB color pixel formats	RGB888, BGR888
Raw pixel formats	RAW8 (monochrome or color)
<b>Operating conditions/dimensions</b>	
Operating temperature	+5 °C to +65 °C housing temperature (with heat sink)
Power requirements (DC)	5 VDC over MIPI CSI-2
Power consumption	Typical: 1.3 W
Mass	10 g (bare board)
Body dimensions (L × W × H in mm)	7 × 26 × 26 (bare board)
Regulations	2011/65/EU, including amendment 2015/863/EU (RoHS)

## Quantum efficiency

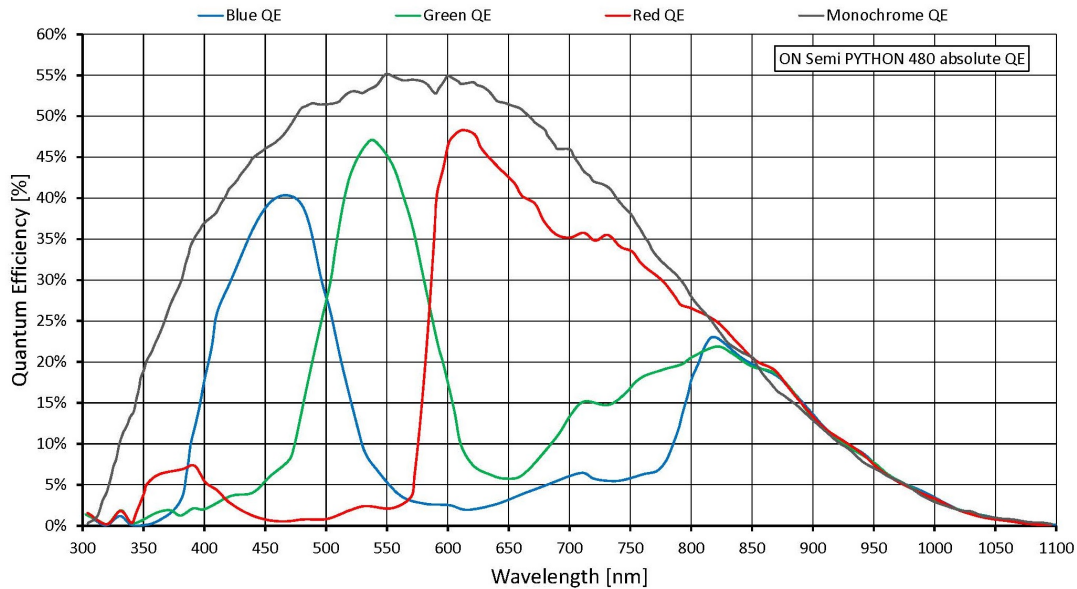

## Features

### Image control

#### Auto control

- Auto exposure
- Auto gain
- Auto white balance

#### Other image controls

- Black level
- De-Bayering up to 5×5 (color models)
- Exposure time
- Gain
- Gamma
- Hue
- Region of interest (ROI)
- Reverse X/Y
- Saturation



Camera control

- Temperature monitoring (sensor board)

## Technical drawing



### Camera hardware options

The [Alvium Cameras Hardware Options](#) document informs about submodels, such as bare board or open housing cameras with different lens mounts.

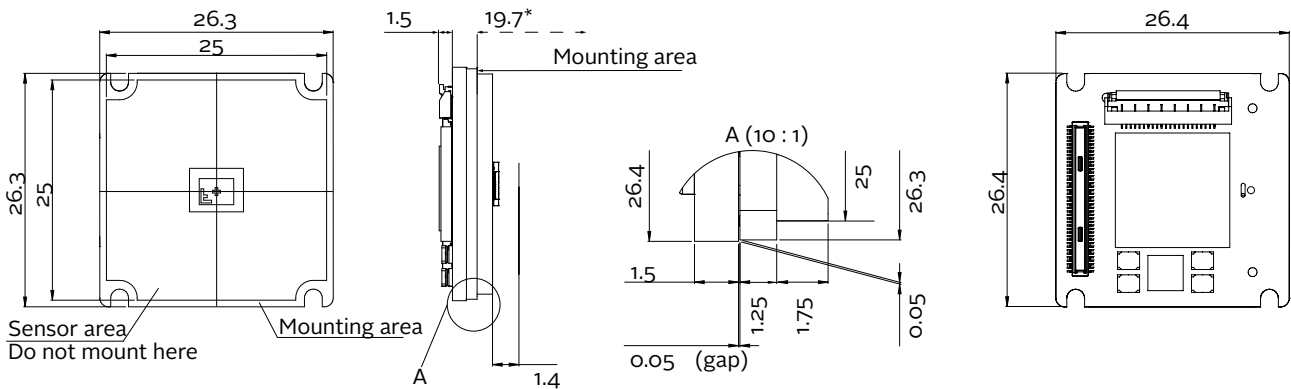

\*Mechanical length for C-Mount, for other mounts and details, see the user guide.



## Applications

Powered by the ALVIUM® Technology, a unique System-on-chip designed by Allied Vision, the Alvium 1500 and Alvium 1800 Series deliver industrial performance to embedded vision with many benefits for system engineers.