



FlatPack® Series Sensor

Close Range | Uneven Surfaces | Reliable | Distance Measurement

MassaSonic® FlatPack® Sensors are low profile designed ultrasonic transmitter modules. They are optimized to provide continuous non-contact distance measurement of fluids, pastes, or uneven solid bulk materials in constrained working zones for application ranges from 1 inch (25 mm) to 13 feet (4 m). Incorporating state-of-the-art dual-transducer ultrasonic technology and processing algorithms, all FlatPack Series Sensors provide precision measurement for factory automation, warehouse materials control, pipe and conveyor belt level monitoring, or tank level applications with non-uniform surfaces.

FlatPack Sensors include an advanced diagnostic feature that will retrieve the ultrasonic waveforms for analysis and display it on a computer to aid users debugging complex installations. All available models are RoHS compliant, CE certified, and IP68 rated. Because of the unique dual transducer design with 15° beam angles, the maximum range capabilities will be less affected by solid materials with uneven surfaces than occurs with single transducer sensors with narrower beam angles.

FlatPack Sensors are field proven designs and come in a PVC housing suitable for use in all-weather resistant moderate chemical environments from -40°C to 70°C. An integrated mounting plate with preformed holes is provided for easy installation. All models are equipped with continuous temperature compensation to ensure precise speed of sound calibration and measurement accuracy. Some other user friendly features include diagnostic and monitoring outputs, protection from over voltage, short circuits, and reverse polarity.

Operating from 12 to 24 V DC, all Massa FlatPack Series Sensors provide a linear output of either 0 to 10 V DC or 4-20 mA, that are proportional to the measured distance to the target. The output range is readily programmable to accommodate a wide variety of user specific set-up and application conditions. In addition, this output voltage can be set to operate as a digital switch within zones defined by specified target set-point distances, enhancing the sensor's flexibility for use in non-routine applications.

The measurement parameters and outputs are programmed using a common standard RS-485 data link to ensure set-up uniformity. Compatible with Microsoft Windows® operating systems using a USB/RS-485 or RS-232/RS-485 converter, up to 32 sensors can be connected in parallel onto the same multi-drop communication network using the supplied protocol. This network also enables users to remotely program their sensors and read target distances for quick integration into control applications. All FlatPack Sensors are adjustable for sampling rate, averaging measurement, analog output slope, loss-of-echo time-out, set point hysteresis (digital switch mode) and provide a software sensor transmit trigger.

Massa FlatPack Series Sensors provides versatile distance measurement for non-uniform liquid or solid surfaces where mounting headroom is restricted or a minimal deadband is desired for accurate ranging with an affordable cost of ownership.



GENERATIONS AHEAD IN SONAR & ULTRASONIC TECHNOLOGY

For more information, please visit www.massa.com, or contact one of our Applications Specialists at: sales@massa.com



FlatPack® Series Sensor

FEATURES

- Dual Transducers and Short Dead Band
- Works on Uneven Solids or Liquids
- Temperature Compensated
- Low Cost of Ownership (CoO)
- Up to 32 Sensors on RS-485 Multi-Drop Network
- Variety of Easy User Programmable Customizations
- Tamperproof & Rugged
- IP68 Enclosure Rating
- Accurate Under Demanding Environmental Conditions

APPLICATIONS

- Liquid Level Control
- Uneven Solids Control
- Bulk Material Management
- Pipe and Conduit Blockage Detection
- Conveyor Belt, Hopper and Chute Monitoring
- Position Detection





FlatPack® Series Ordering Information

FlatPack Series Ordering Code

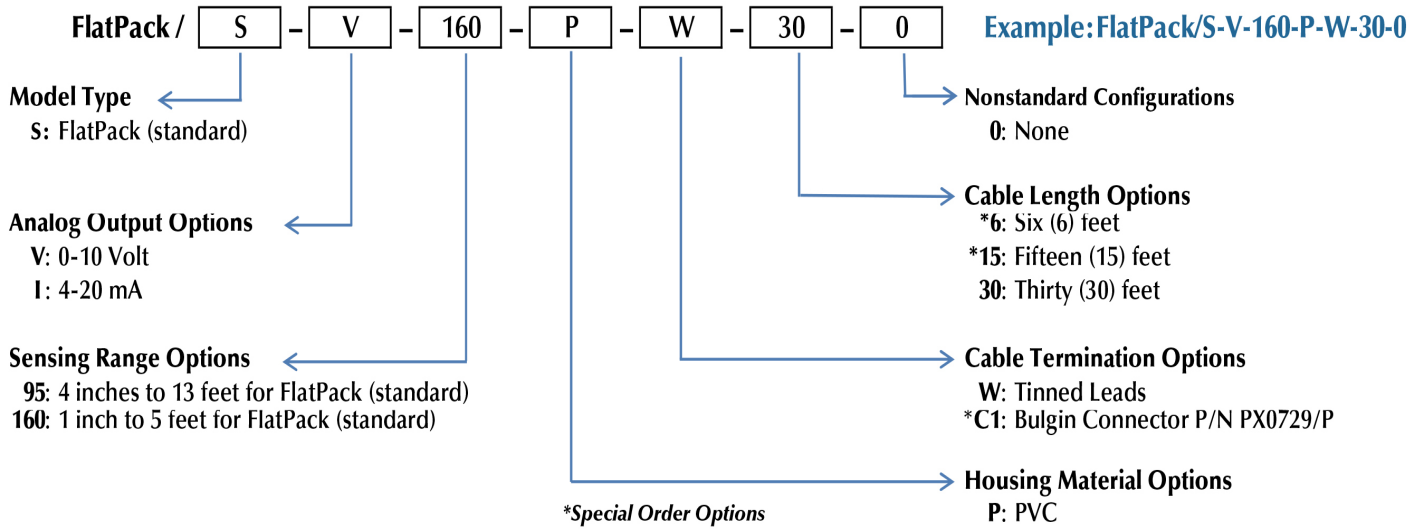

Optional Items:

Serial Port Converters: USB/RS-485, P/N 8448-1 or RS-232(DB9)/RS-485, P/N 7868-1
Massa Software & Manuals: Go to www.massa.com to download the latest versions

FlatPack® Series Performance Specifications

(Typical 24 VDC, 22°C, and 50% RH Air)

Performance		
Target Detection Distances	Short Range (160 kHz) 1 inch (25 mm) to 5 feet (1.5 m)	Medium Range (95 kHz) 4 inches (100 mm) to 13 feet (4 m)
Measurement Resolution	0.01 inches (0.25mm)	
Measurement Accuracy	± 0.1% of Target Range	
Echo Detection Sensitivity	User Selectable	
System Beam Angle	15° Conical	
Response Time	60 mS	
Resolution	11 bits	
Temperature Compensation	Internal Probe	
Mechanical (See Outline Drawings)		
Housing Material	PVC	
Transducer Surface	MassaPlast 102 (custom PPA)	
Cable	5 Conductor, 24 AWG, Shielded, PVC Jacket [User Extendable for RS-485 Communication to 5,000 feet (1,500m)]	
Environmental		
Operational Temperature	-40°C to 70°C	
Storage Temperature	-40°C to 85°C	
Relative Humidity	0 to 95%, non-condensing	
Enclosure Rating	IP68	

All Specifications Subject to Change Without Notice

www.massa.com

FlatPack® Series User Interface Specifications

	Voltage Output Models	Current Output Models
Programmable Outputs	0 to 10 Volts	4-20 mA
Power Required	12 VDC to 24 VDC (reverse polarity protected), 30 mA, typical	12 VDC to 24 VDC (reverse polarity protected), 30 mA, typical (not including I-out)
Setpoints <i>(Programmable options in range min. to > max. detection range)</i>	0 or 10.25 VDC	0 or 20.5 mADC
Output Impedance	100 ohms (both operational modes)	N/A
Current Loop Output	N/A	4 to 20 mA or 0 to 20 mADC sourcing, invertible <i>Factory Default: 4 to 20 mADC</i>
Zero & Span Voltage or Current	Programmable from 0 to 10.25 VDC <i>Factory Default: 0 to 10.0 VDC</i>	Programmable from 0 to 20.5 mADC <i>Factory Default: 4 to 20.0 mA DC</i>
Loss of Echo Voltage or Current	Programmable from 0 to 10.25 VDC <i>Factory Default: 10.25 VDC</i>	Programmable from 0 to 20.5 mADC <i>Factory Default: 20.5 mADC</i>
Zero & Span Distance	Each Programmable over a range from min. distance to greater than max. distance <i>Factory Default:</i> 160 kHz: from 1 inch to 5 feet 95 kHz: from 4 inches to 13 feet	
Trigger Modes	Internal or Software Trigger	
Target Distance Averaging	Rolling Averages: from 1 to 32 samples, or Boxcar Average: from 1 to 1,024 samples <i>Factory Default: 1</i>	
Loss of Echo Time-Out	Programmable from 1 to 254 consecutive samples missed before time-out <i>Factory Default: 1</i>	
Sampling Rate	0.1 Hz to 20 Hz in 0.1 Hz increments <i>Factory Default: 10 Hz</i>	
Communications Converter	USB/RS-485 or RS-232/RS-485 with automatic send data control	
Operating System	Windows 10, 8, 7, Vista, and XP SP3	

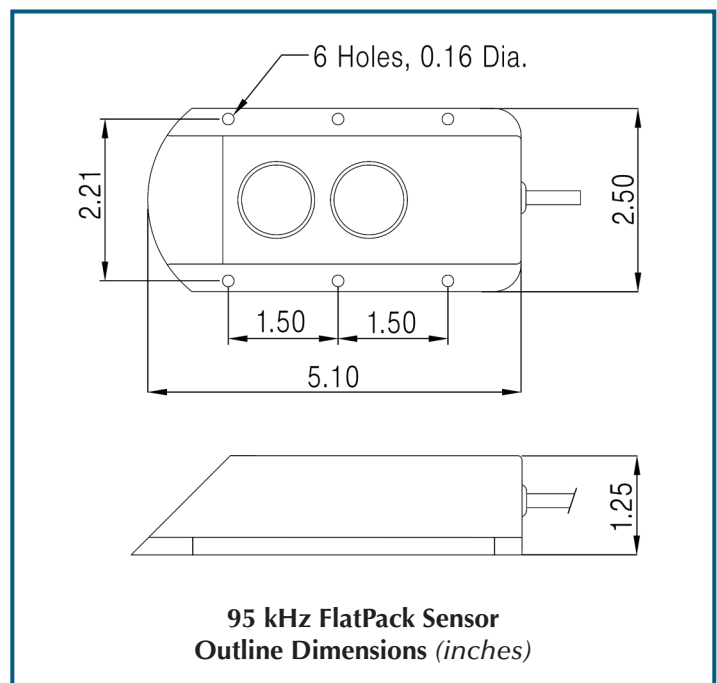
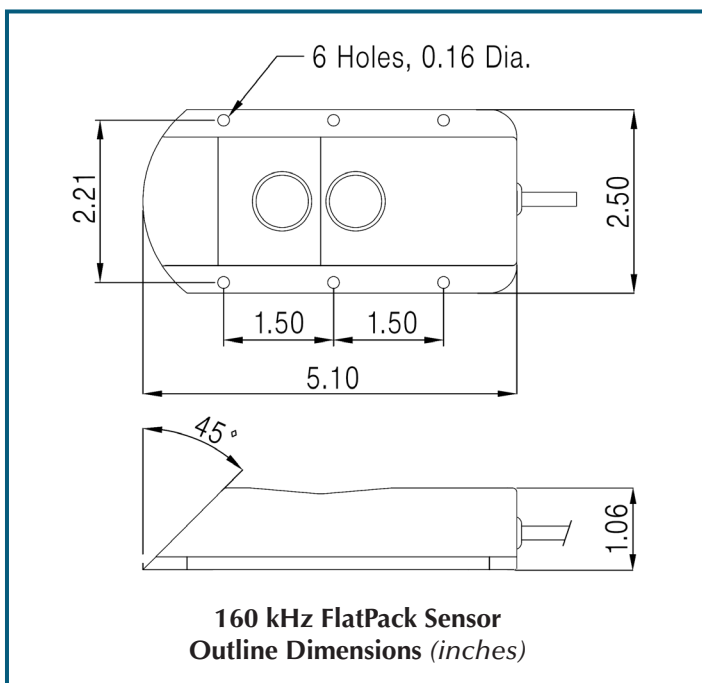



FlatPack® Series Wiring and Connector Information

To operate a MassaSonic® FlatPack® Series Sensor, it is only necessary to connect its red and black wires to a DC battery or power supply (12 to 24 VDC) as shown in the diagram below. The white wire will then indicate the distance to the target or its position to the setpoint.

To change the programmable parameters, or to observe the target distance digitally with the user-friendly software, the sensor can be connected to a computer or other host system with either an optionally supplied USB/RS-485 or RS-232/RS-485 converter. Before more than one FlatPack Sensor can be used simultaneously on the same RS-485 Communication Bus, each sensor must first be programmed with its own unique ID Tag. After this has been completed, the green and brown communication wires for all of the FlatPack Sensors should all be connected in parallel. Terminating resistors are not required for the RS-485 Network.

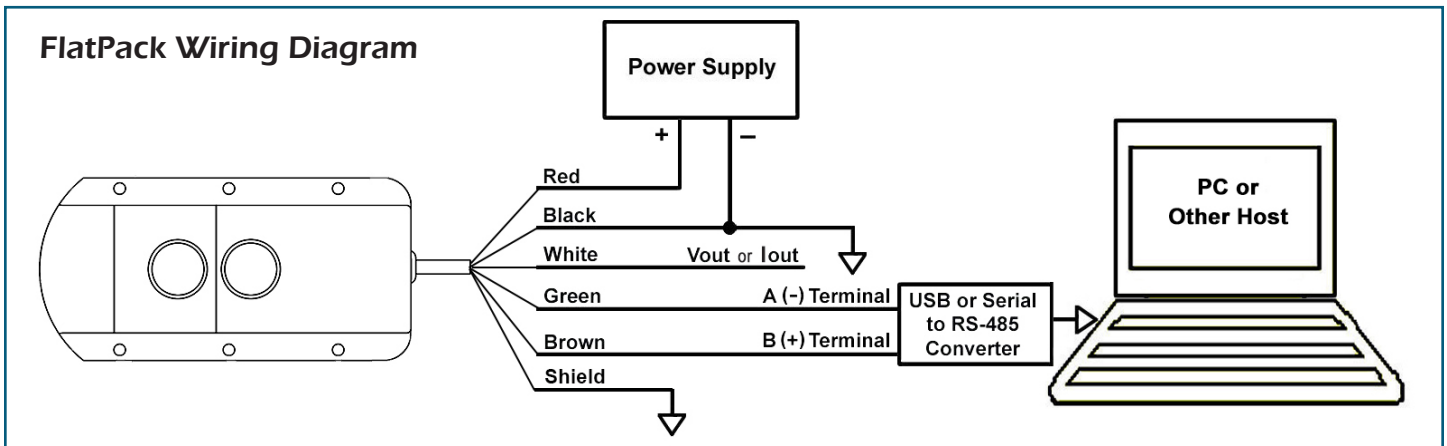

Cable:

5 Conductor, PVC Jacket, Shielded 24AWG

- Red:** +12 V DC to +24 V DC
- Black:** Ground
- White:** Vout
- Green:** RS-485-A
- Brown:** RS-485-B
- Shield:** Ground

Connector:

C1: Bulgin P/N PX0729/P (Mating Connector: P/N PX0729/S)

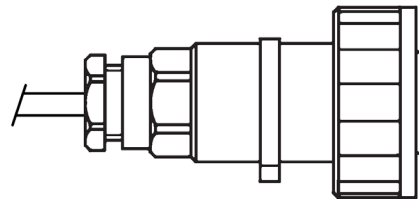

All Specifications Subject to Change Without Notice



GENERATIONS AHEAD IN SONAR & ULTRASONIC TECHNOLOGY

MASSA PRODUCTS CORPORATION | www.massa.com

280 Lincoln Street, Hingham, MA 02043 U.S.A.

Tel: 781-749-4800 or 800-962-7543

For more information, please visit our website or contact one of our Applications Specialist at: sales@massa.com